



**BARTELL
GLOBAL**

**PARTS
BOOK**

RAMMER

BT1000



Doc. # PB-B19026
Orig. Rel. - 06/2016
Curr Rev. - 03

TABLE OF CONTENTS

<u>TANK AND HANDLE ASSEMBLY DIAGRAM</u>	1
○ TANK AND HANDLE - PARTS LIST 1	2
<u>CYLINDER AND FOOT ASSEMBLY DIAGRAM</u>	3
○ CYLINDER AND FOOT ASSEMBLY - PARTS LIST 2	4
<u>CRANK CASE AND ENGINE DIAGRAM</u>	5
○ CRANK CASE AND ENGINE - PARTS LIST 3	6

PLEASE READ THE FOLLOWING CAREFULLY

The manufacturer and/or distributor has provided the parts list and assembly diagram in this manual as a reference tool only. Neither the manufacturer nor distributor makes any representation or warranty of any kind to the buyer that he or she is qualified to make any repairs to the product, or that he or she is qualified to replace any parts of the product. In fact, the manufacturer and/or distributor expressly states that all repairs and parts replacements should be undertaken by certified and licensed technicians, and not the buyer. The buyer assumes all risk and liability arising out of his or her repairs to the original product or replacement parts thereto or arising out of his or her installation of the replacement parts thereto.

TANK AND HANDLE ASSEMBLY DIAGRAM

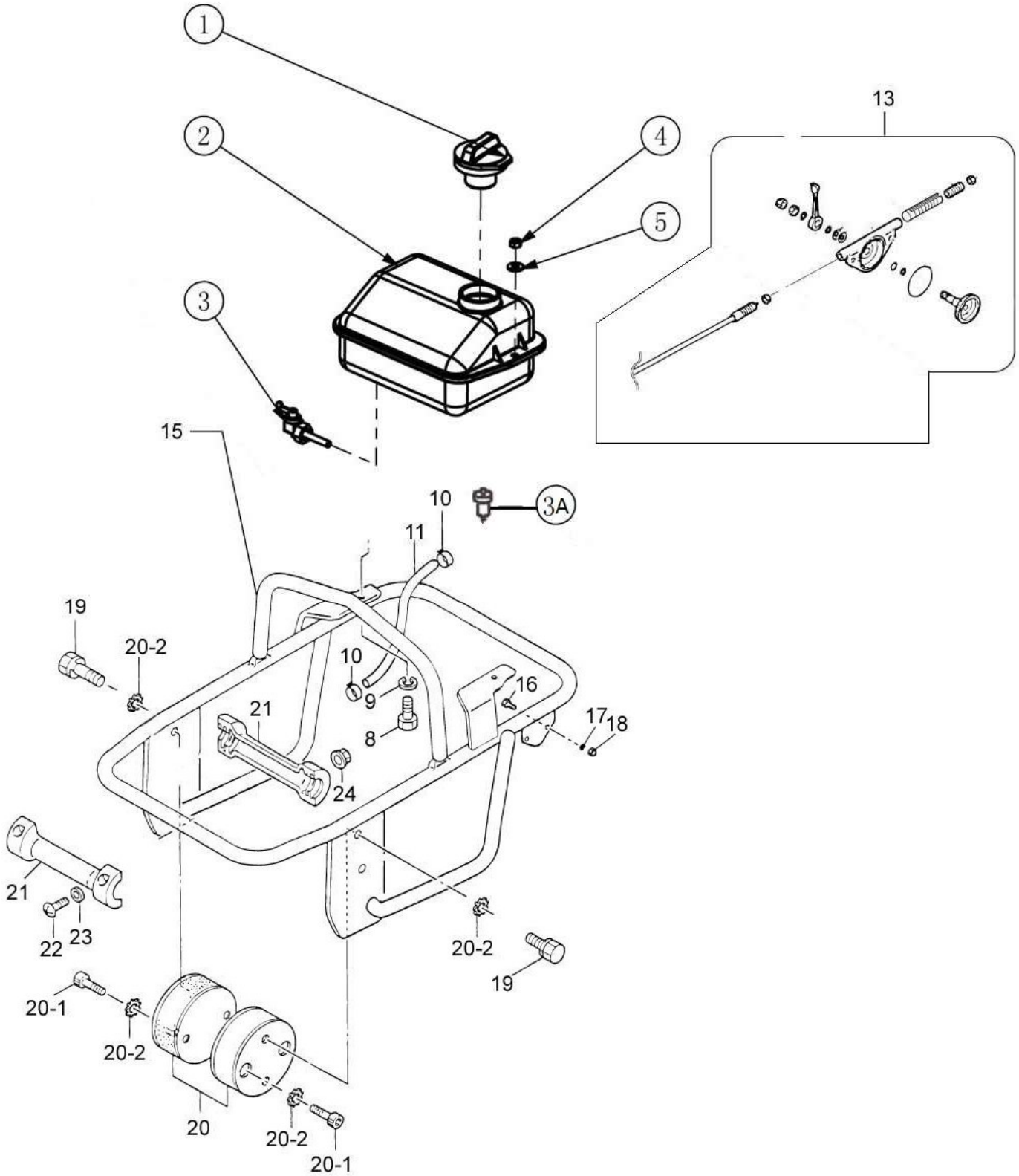

TANK AND HANDLE - PARTS LIST 1

Item	Part No.	Description	QTY	Remarks
1	65CT-66P1-A	FUEL TANK CAP	1	
2	65101	FUEL TANK, COMPLETE	1	
3	65CT-66P1-02A	FUEL VALVE AND SCREEN ASSEMBLY	1	
3a	651159	EXTERNAL FUEL FILTER	1	
4	11617	LOCKNUT, M8	2	
5	11667	WASHER, M8	2	
10	65CT-66P1-06A	HOSE BAND	2	
11	65CT-66P1-07A	FUEL HOSE	1	
13	651050	THROTTLE LEVER ASSEMBLY	1	
15	65CT-66P1-11A	HANDLE	1	
16	51058	HHCS, M6-1.0 x 20MM	2	
17	14448	LOCKWASHER, M6	2	
18	10069	HEX NUT, M6	2	
19	31008	HHCS, M10-1.5 x 20MM	4	
20	65100	SHOCK ABSORBER	2	
20-1	30282	SHCS, M10-1.5 x 20MM	4	
20-2	11621	LOCKWASHER, M10	8	
21	31409	ROLLER	2	
22	60222	HHCS, M5-0.8 x 25MM	4	
23	30846	WASHER, M5	4	
24	30843	LOCKNUT, M5-0.8	4	

CYLINDER AND FOOT ASSEMBLY DIAGRAM

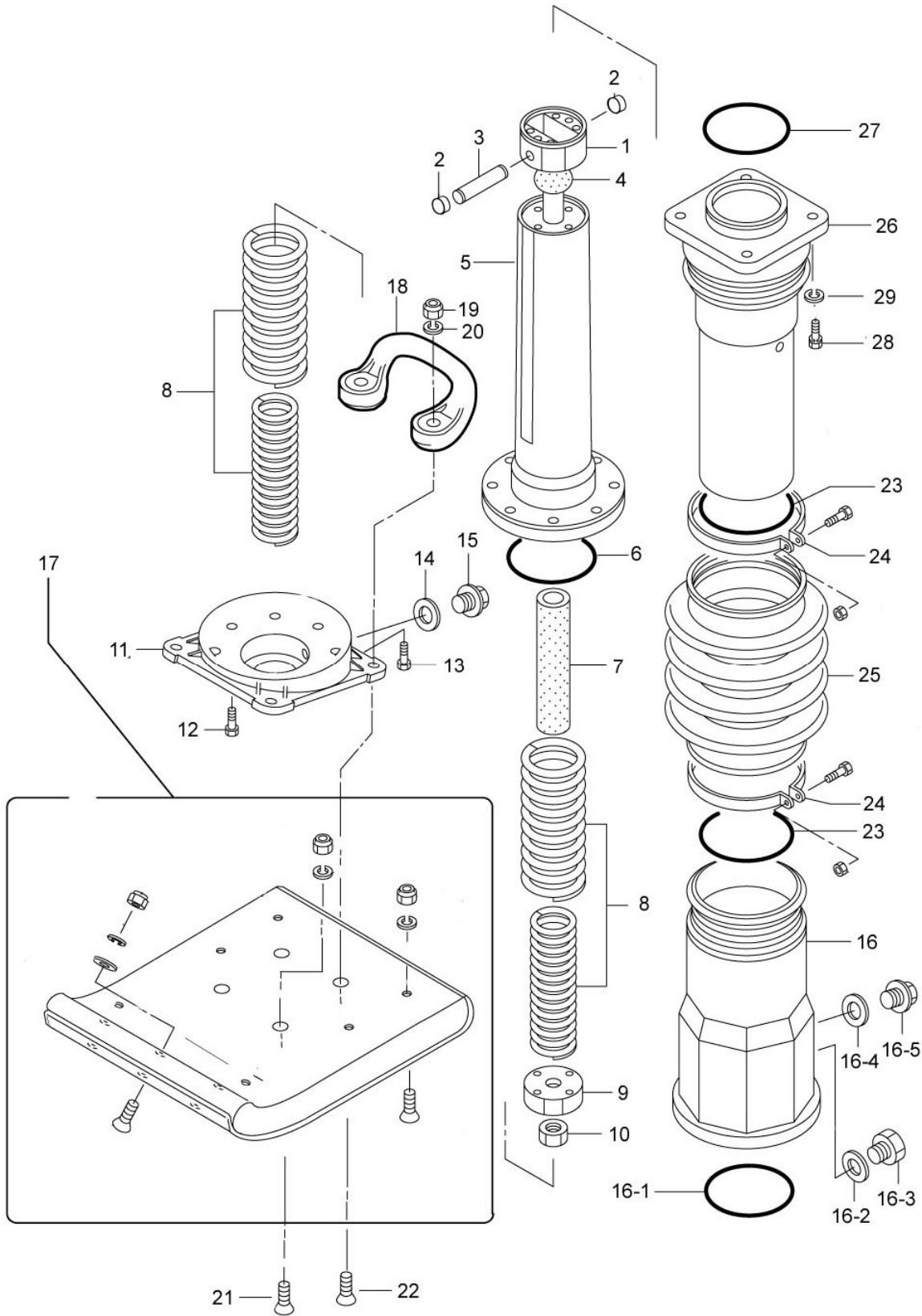

CYLINDER AND FOOT - PARTS LIST 2

Item	Part No.	Description	QTY	Remarks
1	65CT-60P-1C	PISTON ROD	1	
2	65CT-66P1-02C	PISTON PIN END CAP	2	
3	65CT-60P-3C	PISTON PIN	1	
4	65CT-60P-4C	STOPPER, UPPER	1	
5	65CT-60P-5C	SPRING CYLINDER	1	
6	35045	O-RING G-75	1	
7	65CT-60P-7C	STOPPER, LOWER	1	
8	65CT-60P-8C	MAIN SPRING	2	
9	65CT-60P-9C	PISTON END	1	
10	32026	NUT M20-1.5	1	
11	65CT-60P-11C	FOOT PLATE	1	
12	11753	SOCKET HEAD BOLT M10X35T	4	
13	10059	SOCKET HEAD BOLT M10X25T	4	
14	65CT-60P-14C	PACKING M10 (AL)	1	
15	65CT-60P-15C	PLUG M10X1.0X10	1	
16	65CT-60P-16C	PROTECTION SLEEVE	1	
16-1	651194	O-RING, 100MM X 5.3MM	1	
16-2	651210	O-RING, M20	1	
16-3	651211	OIL LEVEL SIGHT GAUGE	1	
16-4	65CT-60P-16-4C	PACKING M16	1	
16-5	65CT-60P-16-5C	PLUG M16X1.5X10	1	
17	65CT-60P-17C	FOOT ASSEMBLY	1	
18	651175	GRIP HANDLEBAR	1	
19	10956	LOCKNUT, M12-1.75	4	
20	10735	LOCKWASHER M12	4	
21	31441	FHSCS, M12-1.75 x 65	2	
22	11916	FHSCS. M12-1.75x70MM	2	
23	651195	O-RING, 170MM X 4MM	2	
24	65CT-60P-24C	BELLOW CLAMP	2	
25	65CT-60P-25C	BELLOW	1	
26	65CT-60P-26C	GUIDE CYLINDER	1	
27	651212	O-RING, 80MM X 3 MM	1	
28	11924	HHCS, M10-1.5 X 40MM	4	
29	11621	LOCKWASHER, M10	4	

CRANK CASE AND ENGINE DIAGRAM

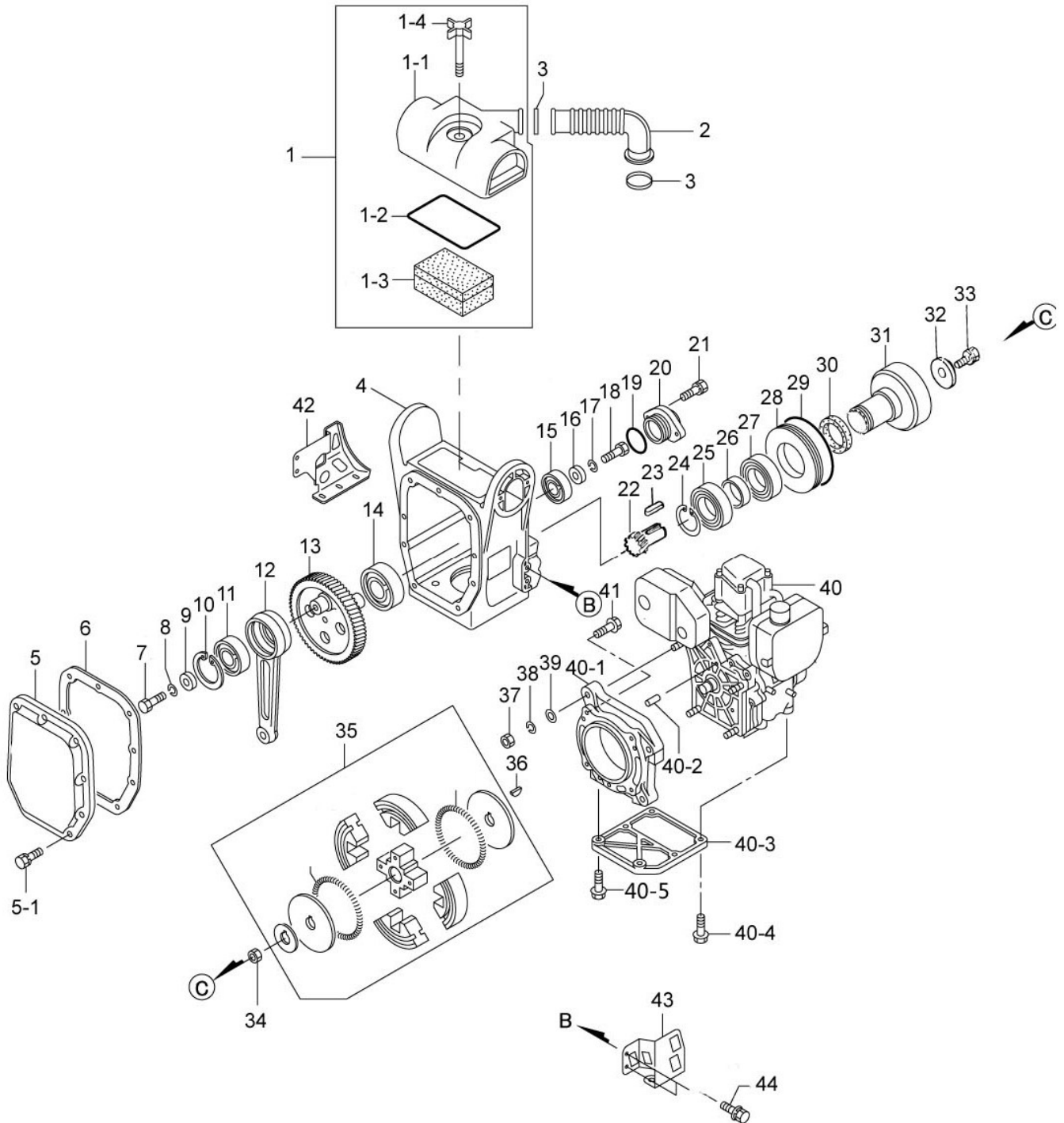

CRANK CASE AND ENGINE - PARTS LIST 3

Item #	Part No.	Description	QTY	REMARK
1	65CT-60P-1B	AIR CLEANER ASSEMBLY	1	
1-1	65CT-60P-1-1B	COVER, AIR CLEANER	1	
1-2	65CT-66P-01-2B	PACKING, AIR CLEANER	1	
1-3	65CT-66P-01-3B	ELEMENT, AIR CLEANER	1	
1-4	65CT-60P-1-4B	GRIP BOLT, AIR CLEANER	1	
2	31387	INTAKE PIPE	1	
3	65CT-60P-3B	CLAMP	2	
4	65CT-60P-4B	CRANK CASE	1	
5	65CT-60P-05B	FRONT COVER	1	
5-1	51058	HHCS, M6-1.0x20MM	9	
6	USE RTV LIQUID GASKET FOR REPLACEMENT		1	
7	11619	HHCS, M8-1.25x25MM	1	
8	11614	LOCKWASHER M8	1	
9	65CT-60P-9B	WASHER 9X30X4	1	
10	31363	STOP RING R-52	1	
11	31437	BEARING 6304	1	
12	65CT-60P-12B	CONNECTING ROD	1	
13	65CT-60P-13B	CRANK GEAR	1	
14	10370	BEARING 6305	1	
15	11379	BEARING 6203	1	
16	65CT-60P-16B	WASHER 8.5X22X3	1	
17	11614	LOCKWASHER M8	1	
18	11619	HHCS, M8-1.25x25MM	1	
19	65CT-60P-19B	O-RING G-35	1	
20	65CT-60P-20B	BEARING COVER	1	
21	51058	BOLT M6X20T	2	
22	65CT-60P-22B	PINION	1	
23	31367	KEY 5X5X19R	1	
24	31373	STOP RING S-35	1	
25	76542	BEARING, 6007	1	
26	65CT-60P-26B	SPACER 35.4-42.7-10	1	
27	31374	BEARING, 6007Z	1	
28	65CT-60P-28B	SPACER, CLUTCH DRUM	1	
29	651196	O-RING, 90MM x 2MM	1	
30	651197	OIL SEAL. 40MM X 52MM X 7MM	1	
31	65CT-60P-31B	CLUTCH DRUM	1	
CONTINUED ON NEXT PAGE.				

CRANK CASE AND ENGINE – PARTS LIST 3 (CONTINUED)

Item #	Part No.	Description	QTY	Remark
32	11667	WASHER M8	1	
33	10999	HHCS, M8-1.25 X 20MM	1	
34	31013	LOCKNUT, M8	1	
35	65102-1	CLUTCH ASSEMBLY	1	
36	65200	WOODRUFF KEY, 4MM X 5MM	1	
37	10193	NUT M8-1.25	4	
38	11614	LOCKWASHER M8	4	
39	11667	WASHER M8	4	
40	-	ENGINE	1	
40-1	65CT-60P-40-1B	ADAPTER, FLANGE	1	
40-2	65CT-60P-40-2B	DOWEL PIN	2	
40-3	65CT-60P-40-3B	STIFFENER	1	
40-4	11619	HHCS, M8-1.25x25MM	2	
40-5	10999	HHCS, M8-1.25X20MM	4	
41	10407M	HHCS, M8-1.25x30MM	4	
42	65CT-60P-42B	OIL GAUGE PROTECTOR	1	
43	65CT-60P-43B	LINK PROTECTOR	1	
44	10999	HHCS, M8-1.25X20MM	4	

This Page Intentionally Left Blank

CONTRACTOR PROVEN EQUIPMENT SINCE 1946



BARTELL GLOBAL

170 Traders Blvd E
Mississauga, ON L4Z 1W7
Canada

4701 Allmond Avenue
Louisville, KY 40209
United States

200 Commerce Drive
Freehold, NJ 07728
United States

Honeyholes Lane
Dunholme, Lincoln LN2 3SU
United Kingdom

