

IF YOU SHOULD EXPERIENCE A PROBLEM WITH YOUR INNOVATECH PURCHASE,  
CALL 1-800-267-6682.

IN MOST CASES AN INNOVATECH REPRESENTATIVE CAN RESOLVE YOUR PROBLEM OVER THE PHONE.  
IF YOU HAVE A SUGGESTION OR COMMENT, GIVE US A CALL. YOUR FEEDBACK IS VITAL TO THE SUCCESS OF INNOVATECH'S QUALITY IMPROVEMENT PROGRAM.

## INSTRUCTION MANUAL

# Innovatech™

## Terminator® T-2100EI Battery Powered Floor Scraper

© Copyright 2012 Innovatech Products & Equipment Co., Everett, Washington USA. All rights reserved.  
**Pat. Num.: 5,641,206**

<b>Table of Contents</b>	
<b>Introduction</b>	<b>4</b>
<b>About This Manual</b>	<b>4</b>
<b>Important Safety Instructions</b>	<b>5</b>
Safety Instructions for All Tools	5
Additional Safety Rules for Riding Floor Scrapers	6
<b>General Operating Instructions for the Terminator®</b>	<b>7</b>
<b>Safety Features</b>	<b>7</b>
Warning Light and Back-Up Alarm	7
Fire Extinguisher	7
Autostop	7
Emergency Battery Disconnect	7
Safety Instructions	7
<b>Terminator® Specifications</b>	<b>8</b>
Tools & Supplies	8
<b>Ventilation Requirements</b>	<b>9</b>
<b>Guards, Warning Notices &amp; Signs</b>	<b>9</b>
<b>Service Instructions &amp; Personnel</b>	<b>9</b>
<b>Replacement Parts &amp; Materials</b>	<b>9</b>
<b>Uncrating The Terminator® And Preparing It For Operation</b>	<b>10</b>
<b>Loading/Unloading Procedures:</b>	<b>11</b>
<b>Operator Controls</b>	<b>11</b>
Drive And Blade Controls And Foot Pedal	11
Auto Stop	11
Emergency Brake	11
Power Limiter	11
<b>Displays and Indicators</b>	<b>12</b>
Battery Display And Hour Meter	12
Hydraulic Oil Over Temperature Indicator	12
Hydraulic Filter Clog Indicator	12
Manual Disconnect And Lockout	12
<b>Electric Motor and Batteries</b>	<b>12</b>
<b>Blade Assembly</b>	<b>13</b>
Taking Up Floor Coverings	13

<b>Ballast .....</b>	<b>13</b>
<b>Tricycle Or Caster Wheelbase And Tires .....</b>	<b>13</b>
<b>Battery Safety .....</b>	<b>14</b>
<b>Hazardous Elements .....</b>	<b>14</b>
<i>Sulfuric acid:</i> .....	14
<i>Explosive Gases:</i> .....	14
<i>Electricity:</i> .....	14
<i>Weight:</i> .....	14
<b>Lifting Batteries .....</b>	<b>15</b>
<b>Wearing Protective Clothing .....</b>	<b>15</b>
<b>Setting Up A Charging Area .....</b>	<b>15</b>
<b>Connecting/Disconnecting Charger .....</b>	<b>16</b>
<b>Basic Charging Facts .....</b>	<b>16</b>
<b>The Charging Process .....</b>	<b>16</b>
<b>Specific Gravity .....</b>	<b>17</b>
<b>Temporary Storage Of Battery Pack .....</b>	<b>17</b>
<b>Check Battery Electrolyte Weekly .....</b>	<b>17</b>
<b>First Aid .....</b>	<b>18</b>
<b>First Aid for Acid Splashes .....</b>	<b>18</b>
<b>Eye Wash And Emergency Shower Facilities .....</b>	<b>18</b>
<b>Maintenance Procedures .....</b>	<b>19</b>
<b>Warranty .....</b>	<b>20</b>
<b>Parts Diagrams .....</b>	<b>21</b>
<b>Electrical Schematic .....</b>	<b>60</b>
<b>Material Safety Data Sheets (MSDS) .....</b>	<b>62</b>
<b>Batteries .....</b>	<b>62</b>
<b>Hydraulic Oil .....</b>	<b>64</b>

## Introduction

The Terminator® Carpet and Tile Removal Machine is intended for use on large demolition and asbestos abatement projects as well as smaller floor covering removal jobs. Designed and built by experienced floor covering demolition and installation experts, the machine incorporates several design features that are essential for efficient operation:

- Tricycle wheelbase and short turning radius allows for better turning ability – especially in narrow spaces.
- Blade vertical and tilt position adjustments allow for positioning the angle of the blade for each application.
- Ballast in front and rear provides extra traction needed for tile and glue removal.
- Built-in forklift transport slots allows for easy loading and unloading at job sites.
- Foot control for a very smooth start and stop.

If operated and cared for as instructed in this Manual, the Terminator® provides trouble-free, safe, and efficient performance.

## About This Manual

This Manual contains the information and procedures to assist you to operate and maintain the Terminator® machine safely and correctly. Read this Manual before you operate or service the equipment. If you need additional information or assistance, please get in touch with our Customer Service Department:

Innovatech Products & Equipment Co.  
832 80th ST SW  
Everett, WA 98203 USA  
(425) 402-1881 or 800-267-6682  
Fax (425) 402-8547  
Email: [service@InnovatechProducts.com](mailto:service@InnovatechProducts.com)

NOTE: Throughout this Manual directional instructions (left, right, up, down, push, pull, etc.) are given from the point of view of the operator performing the action.

## Important Safety Instructions



**WARNING:** When using electric tools, basic safety precautions should always be followed to reduce the risk of fire, electric shock, and personal injury, including the following:

### **READ ALL INSTRUCTIONS**

### **Safety Instructions for All Tools**

- **KEEP GUARDS IN PLACE** and in working order.
- **REMOVE ADJUSTING TOOLS AND WRENCHES.** Form habit of checking to see that keys and adjusting wrenches are removed from the Terminator® before turning tool on.
- **KEEP WORK AREA CLEAN.** Cluttered areas invite accidents.
- **KEEP CHILDREN AWAY.** All visitors should be kept a safe distance from the work area.
- **WEAR PROPPER APPAREL.** No loose clothing, gloves, neckties, rings, bracelets or other jewelry to get caught in moving parts. Non-slip footwear is recommended. Wear protective hair covering to contain long hair.
- **ALWAYS WEAR SAFETY GLASSES.** Also use a face or dust mask if operating in a dusty environment. All users and bystanders must wear eye protection that conforms to ANSI Z87.1. (CAN/CSA Z94.3)
- **MAINTAIN EQUIPMENT WITH CARE.** Keep equipment clean for best and safest performance. Follow instructions for lubrication and changing accessories.
- **DISCONNECT BATTERY** before servicing.
- **REDUCE THE RISK OF UNINTENTIONAL STARTING.** Make sure handles are centered and foot pedal is not depressed before starting.
- **USE RECCOMENDED ACCESSORIES.** Consult the instruction manual for recommended accessories. The use of improper accessories may cause risk of injury to persons.
- **NEVER STAND ON TOOL.** Serious injury could occur if the machine is tipped or rocked.
- **CHECK DAMAGED PARTS.** Before further use of the tool, a guard or other part that is damaged should be carefully checked to determine that it will operate properly and perform its intended function—check for alignment of moving parts, binding of moving parts, breakage of parts, mounting and any other conditions that may affect its operation. A guard or other part that is damaged should be properly repaired or replaced. Do not use tool if switch does not turn it on and off.
- **NEVER LEAVE EQUIPMENT RUNNING UNATTENDED. TURN POWER OFF.** Don't leave equipment until it comes to a complete stop.
- **DO NOT OPERATE ELECTRIC TOOLS NEAR FLAMABLE LIQUIDS OR GASSES OR EXPLOSIVE ATMOSPHERES.** Motors in these tools may spark and ignite fumes.

## **Additional Safety Rules for Riding Floor Scrapers**

**⚠ CAUTION: FAILURE TO HEED THESE WARNINGS MAY RESULT IN SERIOUS PERSONAL INJURY OR DEATH AND SERIOUS DAMAGE TO THE TERMINATOR®.**

The Terminator® is to be operated only by qualified, trained personnel.

DON'T attempt to operate the Terminator® if you are not thoroughly familiar with the operation of the Terminator®.

DON'T operate the Terminator® unless every guard, warning notice or sign is in place.

DON'T use the Terminator® on roofs or floors not designed to carry the weight of the machine. The Terminator weighs 2,780 lbs.

DON'T attempt to operate on anything but the designated voltage.

DON'T operate unless all clamp handles are tight.

DON'T wedge anything against the motor fan to hold motor shaft.

DON'T operate equipment without guards in place.

DON'T operate the Terminator® near an open flame or smoking materials

DON'T operate the the Terminator® while under the influence of drugs, alcohol or medication.

DON'T engage in horseplay on or near the Terminator®

DON'T stand directly behind or in front of the the Terminator® when power is enabled.

DON'T lift the hood, inspect the blade, or otherwise service or maintain the Terminator® while power is enabled.

DON'T operate the Terminator® if the top cover is open.

DON'T overreach. Keep proper footing and balance at all times.

DON'T run the machine into piles of debris, as this may cause the machine to become unstable and tip over.

DON'T sit on or stand next to, under or around the Terminator® when it is being transported in a moving vehicle, whether by itself or with other equipment.

DON'T attempt to use the Terminator® on a non-horizontal surface or turn the Terminator® around on a ramp or hill.

DON'T put your hands or feet in the blade area when the Terminator® is running.

DO turn the power off when not in use.

DO use personal safety equipment such as steel toe shoes, safety glasses, gloves, and ear plugs.

DO use gloves when changing blades and removal tools. Tools may be hot and cause burns.

DO familiarize yourself with all safety features and controls before each use.

DO use the Terminator® only for the purpose for which it was designed. Attempting to alter the Terminator® will invalidate applicable warranties and possibly damage the machine.

DO reduce speed next to walls, machinery and other objects.

DO pre-survey the floor for cracks, ditches, trenches, electrical outlets or bolts, which could catch the blade of the machine.

DO use the seat belt on the machine.

DO operate the Terminator at a safe speed.

## General Operating Instructions for the Terminator®

- The Terminator® is designed to remove carpet, tile and glue residue from floors.
- When removing product, position removed product so it rolls to the side of the machine or have someone on the side of the machine remove the product. NEVER WALK IN FRONT OF OR BEHIND THE TERMINATOR® WHILE IT IS RUNNING.
- Sharpen blades or dice material into narrower widths if machine slows down or seems to be struggling.
- Do not use the Terminator® within one foot of walls or stationary objects. Damage to objects may occur if the Terminator® strikes them.
- Use safe, OSHA approved tools and methods for sharpening blades.
- Make sure the Terminator® has a charged fire extinguisher, working back up beacon and strobe light before operating.

## Safety Features

The Terminator® is equipped with several features to help ensure your safety and the safety of workers around you.

### Warning Light and Back-Up Alarm

An amber light is installed on the top rear section of the hood. When the Terminator's® ignition is in the ON position, the warning light will flash. When the drive control is set in REVERSE, the back-up alarm sounds to warn people nearby that the machine is backing up.

### Fire Extinguisher

A fire extinguisher with gauge is installed on the hood behind the operator's seat, within the operator's reach. As a safety measure, regularly inspect the gauge and recharge the fire extinguisher as needed to maintain full capacity. Always recharge the extinguisher after each use.

## Autostop

The Terminator® has two drive levers located to the right and left of the operator seat and a blade height lever to the left of the operator seat. The drive levers control the forward, reverse, left, and right directions of the machine; the blade height lever raises and lowers the blade. You must push (forward) or pull (reverse) and hold the levers in position to drive the machine or move the blade in the direction desired. When you release a lever, the Terminator® or blade automatically STOPS and will not move again until you push/pull and hold the levers again. However, these levers are not meant as brakes. Block wheels with a floor block when stopping on a ramp and use the emergency brake. Without the emergency brake the machine may roll forward or backwards on any sloping surface.

## Emergency Battery Disconnect

To the right side of the operator seat is a red disconnect switch with a key. This disconnect will remove power from the motor and other electronic components. Warning! Removing power from the Terminator® while on a hill or ramp can lead to a dangerous rollaway situation. Always engage the parking brake before disconnecting power.

## Safety Instructions

The Terminator® is designed for safe operation by trained, designated personnel. To help ensure your safety as a designated operator, read these safety instructions before you operate the equipment. Regardless of your experience with machinery, the Terminator® has unique features and systems which you need to know about and understand before you operate or service the machine.

## Terminator® Specifications

Element	English	Metric
Length	63.5"	1612.9 mm
Width	26.5"	673.1 mm
Height	52"	1320.8mm
Weight*	2830 Lbs	1283.7 Kg
Tires	15" OD x 8" W	381 mm OD x 203 mm W
Motor Voltage	48 VDC	
Motor Power	10 HP	7.5 KW
Batteries	6 VDC 415AH	
Motor Operating Speed	0 -3600 RPM	
Hydraulic Oil Type	ISO 46	
Hydraulic Oil Capacity	11 Gal	41.6 L
Hydraulic Relief Valve Pressure	2200 PSI	15.16 MPa

\*Weight includes the base machine and 1 Rear Weight, 3 Front Weights and 2 Wheel Weights.

### Tools & Supplies

Maintenance tools and supplies are not provided with the machine. You are responsible for purchase of these items. The following are suggested items to have on the job site.

- |   |   |
|---|---|
| <ol style="list-style-type: none"> <li>1. 4" or 7" Grinder</li> <li>2. 10"-15" Crescent Wrench</li> <li>3. 16-20 oz. Hammer</li> <li>4. 3/8" or 1/2" Socket Set</li> <li>5. Grease Gun</li> </ol> | <ol style="list-style-type: none"> <li>6. WD 40</li> <li>7. 3/4 Open End and Box Wrench</li> <li>8. Screw Driver Set</li> <li>9. Safety Glasses</li> <li>10. Ear Plugs</li> </ol> |
|---|---|



## Ventilation Requirements

Charge the batteries only in well-ventilated areas. (See Battery Safety section)

## Guards, Warning Notices & Signs

The guards, warning notices and signs are placed on the Terminator® for your protection. If one of them becomes damaged or is lost, contact our Customer Service Department to order a replacement.

## Service Instructions & Personnel

Like other machinery, the Terminator® requires regular inspection and maintenance of the batteries, motor, hydraulic system and other parts. To prolong the safe and efficient operating life of the machine, clean and service it as instructed in the Maintenance section of this manual.

**Always** use trained personnel to service the equipment. **Never** allow anyone to service the equipment that has not been specifically trained to do so.

If you need help with a service or maintenance problem, contact our Customer Service Department.

## Replacement Parts & Materials

The Terminator® is designed and engineered to operate safely and efficiently with the parts and materials installed on it in our factory. To ensure the continued safe and efficient operation of the equipment, use replacement parts and materials that meet both of the following requirements:

- Innovatech must solely authorize replacement parts and materials.
- Replacement parts and materials must be identical to the items originally provided with the machine, except as authorized by Innovatech.

Never use “equivalent” or substitute parts, except as expressly authorized by Innovatech.

If you fail to adhere to these instructions, you may cause injury to yourself and/or others, cause damage to the Terminator®, and invalidate applicable warranties.

If you are in doubt about any replacement parts or materials, call our Customer Service Department for assistance.

## Uncrating The Terminator® And Preparing It For Operation

When you receive the Terminator®, inspect the outside of the crate completely, to detect damage to the crate itself. If it is damaged, notify the carrier immediately and follow his/her instructions to file a claim.

Carefully uncrate the machine and inspect it for damage that may have occurred during shipping. If the shipment is damaged, notify the carrier immediately and file a claim in the normal manner.

Check packing slip for complete shipment. If shipment is incomplete, notify our Customer Service Department within 24 hours.

Remove the crate debris, set aside the blades and other packages, and prepare the Terminator® for operation:

Raise the hood and prop it open with the hood brace. Be sure the tip of the brace is firmly secure under the latch. **DO NOT MOVE THE TERMINATOR® MACHINE WITH THE LID OPEN!**

Inspect batteries for spillage during shipment. Check battery water levels before starting the Terminator®.

**CAUTION! Wear acid-resistant gloves and safety glasses and use extreme care when checking battery water levels. DO NOT WORK NEAR A FLAME OR SPARKS.**

### To remove the TERMINATOR® from crate with a forklift:

1) Remove footrest by pulling the clevis pins out, which are located on the right and left hand sides, then disconnect the throttle cable. Pull out footrest; this will then expose the forklift slots.

### To remove the TERMINATOR® from crate without a forklift:

- 1) Plug the battery connectors together.
- 2) Take 2 x 4's off the edge of the crate and between the wheels.
- 3) Place 2 x 4's behind the crate of the rear of the machine.
- 4) Make a ramp with the 2 x 4's and the crate material.
- 5) To enable power to the TERMINATOR®, turn the key, pull up on red knob.
- 6) Depress foot pedal to start motor. Lift front wheel off of the crate 5 inches by pulling back on the valve handle. (Front blade holder will be on crate).
- 7) Pull back the left and right handles evenly and depress the foot pedal slowly. The machine will start moving slowly backwards.
- 8) Ensure that both rear wheels come off the crate evenly. Failure to back off evenly could result in the machine tipping over and harm to the operator.
- 9) As machine moves back, ensure that the center wheel clears the crate. If center wheel does not clear the crate, depress the center handle while pressing the foot pedal until the wheel clears the crate.
- 10) Once machine is on the ramp, slide all the way to the bottom, then lift jaw up and set center wheel down to the ground.
- 11) Whenever mounting or dismounting the TERMINATOR®, ALWAYS disable the power by pressing down on the red power knob.

## Loading/Unloading Procedures:

- Do not load or unload the Terminator® on uneven ground.
- Ensure ramps into moving vehicles are stable and square to the ground.
- Always turn the Terminator® OFF when you transport the Terminator® by forklift or other vehicle.
- Load and unload the machine with a properly weighted forklift or lift-gate.
- Make sure all safety stops are installed on a lift-gate before loading or unloading.
- Never position yourself under or around the machine while moving it with other machinery.
- Park the machine with the blade completely down after loading.
- Properly secure the machine with chains, tire chocks, and other necessary tie downs.
- Never ride in a moving vehicle next to a Terminator®. It may tip, causing severe injury.

## Operator Controls

The operator controls consist of the drive and blade height levers, foot pedal, manual disconnect, and a power limiting.

### Drive And Blade Controls And Foot Pedal

The drive and blade controls (three levers) are located to the left and right of the operator seat. The drive levers (left and right) control the direction of rotation of the rear wheels. The blade height lever controls the vertical position of the blade. The foot pedal controls the speed of the hydraulic pump. The levers only work when the foot pedal is partially depressed and the pump is running. Operation of the drive levers is as follows.

From the view of the seated operator:

Push the left and right levers forward **together** and hold them

**Terminator T-2100EI Manual**

in position then slowly depress the foot pedal to move the machine forward.

Pull the left and right levers back **together** and hold them in position then slowly depress the foot pedal to move the machine in reverse. (The alarm sounds.)

Push only the left lever forward to turn the machine to the right.

Push only the right lever forward to turn the machine to the left.

To adjust the blade down, push and hold blade lever forward and press the foot pedal to move the blade down. To adjust the blade up, pull and hold the blade lever back and press the foot pedal to move the blade up.

### Auto Stop

When you release the drive or blade lever, the motor continues to run (with foot control depressed) but the drive or blade motion automatically stops and will not start again until you push or pull the levers again.

### Emergency Brake

The Terminator® is supplied with an emergency brake to prevent an intended movement when left unattended. The brake handle is located to the left of the operator seat. Pull the handle up to engage the brake, push the handle down to release the brake. To increase tension on the brake you can rotate the end of the handle in a clockwise direction. Rotate the end of the handle counter clockwise to reduce the tension.

### Power Limiter

The power limiter allows the top output speed to be set from 70% to 100%. This will allow you to conserve power during normal operation when top speed is not required. (Increasing motor power will reduce the run time of the machine)

## **Manual Disconnect And Lockout**

The manual disconnect is located to the right side of the operator seat. To enable operation of the Terminator® unlock the manual disconnect lock and pull up. In case of emergency push down to remove power from all electrical components. Always push down this switch to OFF when the Terminator® is not in use.

## **Electric Motor and Batteries**

The electric motor and batteries are located under the top cover. The electric motor provides the power to the hydraulic pump to drive the Terminator®.

The electric motor requires little maintenance, inspect wire connections and check for debris to maintain its efficiency and prolong its operating life.

Battery life can be ensured by proper periodic maintenance. Ensure that battery water levels remain sufficiently high to cover the battery electrode plates. Distilled or de-ionized water can be used to replace lost water. Avoid using tap or well water as the minerals present can reduce the effectiveness of the batteries and shorten battery life. Batteries should be charged before placing the Terminator® into long term storage. The stored battery should be charged monthly when not in use to prolong battery life. A maintenance charge cycle should be performed every 5th charge to maintain optimum battery performance.

## **Displays and Indicators**

### **Battery Display And Hour Meter**

The battery display shows pump use time, key power time and battery life. (When the last box starts to blink, you have about 15 minutes before battery power is exhausted.)

### **Hydraulic Oil Over Temperature Indicator**

Normal temperatures are below 120°F. Do not allow the hydraulic fluid to exceed 200°F because it may damage the hydraulic system and in turn, damage the Terminator®. If the indicator light is continually coming on, turn machine off and let it cool for 45-60 minutes. If the light regularly turns on, call Innovatech Service Department. If you regularly work in a hot climate you may need a hydraulic cooler.

### **Hydraulic Filter Clog Indicator**

The hydraulic oil filter is equipped with a clog indicator which will illuminate when the hydraulic oil filter is clogged. (Note: The indicator may also inadvertently come on in cases when the hydraulic oil is very cold, the light will stop illuminating once the hydraulic oils has warmed to normal operating temperature.)

## Blade Assembly

Blades are available in different configurations and thickness. An assortment of blades is included in the purchase price of the Terminator®. Extra blades are available upon request from Innovatech Products & Equipment Co., Inc.

### Installing a Blade

- 1.) Raise the blade assembly to maximum up position, which is five inches off the floor.
- 2.) Unwrap the pre-sharpened blades and select the blade thickness and length you need for the job.
- 3.) Loosen the 7 holding bolts.
- 4.) Insert the sharpened blade.
- 5.) Tighten bolts firmly, starting from the center and working out. Bolts should be snug but not over tightened.

### Taking Up Floor Coverings

- 1.) Insert blade. (As explained above)
- 2.) Lower blade to floor. Lift caster wheel off the floor ¼ inch. Use previous procedures to drive forward.
- 3.) As the Terminator® is removing flooring material, it is recommended to have another person at the side of the machine remove all debris.

## Ballast

The Terminator® is equipped with weights in front (75 pounds each) and rear (125 pounds each) to provide traction for tough jobs. These weights can be removed to reduce traction for certain jobs, and to transport the Terminator® by forklift or truck or elevator. Wear gloves when handling these weights. Use caution to not smash toes and fingers. Use OSHA approved lifting technique.

## Tricycle Or Caster Wheelbase And Tires

The tricycle wheelbase allows better turning ability. The wheel bearings on the front caster roller require lubrication with grease every 30 hours of machine operation. There are three fittings, two on the wheel and one on the housing. When running over debris such as carpet, the carpet yarn will get caught between the wheel and the housing. Clean out wheel and housing regularly.

The rear tires are solid rubber, tubeless, and require no maintenance. Over time, they may wear out and need to be replaced. Before each job, inspect the rear tires and lug bolts. Tighten the lug bolts as needed to 70 foot-pounds torque. It is important to keep the lug bolts tight.

Wheel hub should be tightened from 310 to 350 ft.-lbs. Inspect and re-torque every 60 hours of operation. Lift machine off of floor so no weight is on wheel when re-torquing pack nut.

## Battery Safety

### Receiving the Terminator®

After receiving the Terminator®, examine the covers and battery catch tray for signs of damage. Attention should be given to the crate and pallet of the Terminator® when it arrives for any damage that may have happened during shipment. If you see any dented or crushed housing parts contact Innovatech for procedures to repair shipping damage. If you see wet areas, the batteries may have been tipped during shipping.

Every cell should be inspected to be sure that the electrolyte is above the battery plates.

Only trained or authorized personnel should change, repair or charge batteries.

When used properly, a lead-acid motive power battery is a safe, dependable source of electrical power. However, if proper care and safety precautions are not exercised when handling a battery, it can be an extremely dangerous piece of equipment.

There are four hazardous elements in a lead-acid battery.

1. Sulfuric acid
2. Explosive gases
3. Electricity
4. Weight.

### Hazardous Elements

#### *Sulfuric acid:*

The electrolyte in a lead-acid storage battery is a diluted solution of water and sulfuric acid. Although the acid content in the solution is only about 37%, it is still a strong corrosive agent and can burn skin and eyes as well as devour many types of fabric. (See Wearing Protective Clothing.)

Specific Gravity Reading	% Acid Content by Weight
--------------------------	--------------------------

1.280	37.40
1.290	38.55
1.325	42.50

#### *Explosive Gases:*

When a lead-acid battery is being charged, it produces a small explosive mixture of hydrogen and oxygen gases. Make sure that all vent caps are unclogged and securely attached so that any gas is safely vented from the battery enclosure. Never smoke, use an open flame or create an arc or sparks on or near a battery without first eliminating explosive gases from the cells you are working on.

(See Setting Up Charging Area Section Below)

#### *Electricity:*

An electrical shock hazard exists for any person who comes in contact with a battery over 50 volts, this is one of the reasons that the Terminator 2000ei battery pack has been limited to 48 volts for maximum power potential as well as maximum safety. In addition, metallic objects coming in contact with exposed cell connectors will cause a short circuit resulting in the metallic object heating up to a high temperature. Even shorts involving a single cell can become hot enough to cause severe burns. Any tools used on or around the Terminator 2000ei should be covered with a plastic coating or heat shrink.

#### *Weight:*

The Terminator® 2100EI has a battery pack weighting up to 1000 pounds. It can cause serious injury if it is not handled carefully during installation, removal or transport. Use proper lifting equipment and techniques at all times.

## Lifting Batteries

Always use proper lifting equipment to reduce the risk of battery damage, shorting and possible injury. An insulated lifting device used with an overhead hoist is the safest way to move a battery. Chain hoists used to handle batteries should be equipped with a non-metallic container or bucket to prevent the chains from dangling and possibly causing a short by coming in contact with exposed cell connectors on the battery top.

Never lift batteries by the inter-cell connecting cables. Connectors on these cables are designed for maximum current flow and not strength. The connectors will suddenly come apart while the battery is in midair. Connect lifting device to negative terminal only if there is not a lifting strap in place. Lifting by both terminals could cause the negative and positive terminals to be shorted together.

## Wearing Protective Clothing

When working on or near batteries, always wear proper protective clothes including a face shield, safety glasses, long sleeved shirt, and acid-resistant gloves. Do not wear any metal jewelry including rings, as they can short circuit a battery and become extremely hot if it accidentally contacts exposed inter-cell connectors.

## Setting Up A Charging Area

All owners of the Terminator® 2100EI need to designate a charging area, to charge the battery pack at the end of a workday or while storing the Terminator®.

This area should have all the proper battery handling equipment including the spill kit supplied with the Terminator® 2100EI.

The area needs to be well ventilated even when the battery is only being trickle charged.

Ventilation is considered satisfactory if the hydrogen concen-

tration does not exceed 1.5% - 2% in any one location. Concentrations of more than 4% are explosive and dangerous.

A prominent NO SMOKING sign should be posted as a reminder.

Factors for determining proper ventilation include the number of Terminator® 2100EI machines or other battery operated machinery such as forklifts that are stored in the location, as well as the size, height and air-tightness of the storage location. A number of instruments, such as combustible gas indicators and flammable vapor indicators, are available for continuous and automatic analysis of hydrogen content in the air. A floor standing fan or box fan will help significantly to disperse off gassing.

A source of running water nearby is desirable other than the distilled water used to top up battery cells. A water hose is recommended at the charging and filling station.

The floor in the battery charging and filling area should have an acid resistant coating and able to be washed down with clean water after a spill. The spill should be neutralized with Baking Soda or Soda Ash before it is cleaned up. While Soda Ash is relatively safe to handle, being very similar to Bicarbonate of Soda, both of these chemicals will react with sulfuric acid to produce Carbon Dioxide, which is a gas that is heavier than air and tends to collect in low places if not ventilated properly.

Carbon Dioxide is a non-toxic gas normally present in the air, which can reduce the oxygen content of the air from the normal 21% by dilution or displacement. Air containing 16% or less oxygen may cause injury or even death to a person breathing in such an environment. While good ventilation will control the carbon dioxide hazard in open spaces, extra special care must be taken when neutralizing significant quantities of sulfuric acid in closed areas with the above type of chemical.

Lime, caustic soda and ammonia or ammonium hydroxide do not release carbon dioxide when neutralizing sulfuric acid but

are very strong chemicals themselves and should ONLY be used by qualified, chemically trained individuals.

### **Connecting/Disconnecting Charger**

Always turn the charger off at the charging unit before connecting or disconnecting the battery charger leads. The Battery Connector below the seat is shipped in a disconnected state; this connector will have to be plugged in order to operate the Terminator® 2100EI.

It is also good practice to leave this main power connector unplugged during storage.

Live leads can cause arcing and sparks which could cause an explosion if battery gases are present, please check that the main contactor/disconnector is not in the on condition when you connect or disconnect the battery terminal plug. In addition, the battery connector terminals will become pitted over time resulting in poor connections and increased heat generation in the battery leads and connectors.

### **Basic Charging Facts**

- Proper charging is essential for maximum battery life.
- In general, the proper charging rate is any rate that does not produce a battery temperature higher than 115F or 46C, and or does not produce excessive gassing.

\* The Terminator® 2100EI is supplied with a CEN 48V 50 Amp charging unit, which has been sized to give optimum charging time without causing excessive heating or off gassing.

\* Do not use a 12v battery charger on the Terminator® 2100EI battery pack this will cause damage to the charger as well as the battery pack.

\* When a discharged battery is initially placed on charge, it will draw a current equal to or close to the chargers maximum output. As the battery voltage rises back to its rated voltage the

chargers output will adjust down automatically to assure a safe, efficient charging rate during all stages of the charge

\* The CEN Charger is designed to start and stop so as not to under or over charge the battery pack. The “smart” charger has a computerized control unit, which can determine when the battery is fully charged and then automatically end the charge cycle.

There are two important types of charge that are used for lead-acid deep-cycle batteries, Standard Re-charge and an Equalizing Charge.

*Standard Re-charge:* After a battery has undergone a normal full shift and has been fully or partially discharged, it must undergo a standard charge. Normally a standard recharge is based on an 8-hour charging cycle.

*Equalizing Charge:* Due to a slight difference in the construction of each battery cell, some cells take less charge than others. An occasional equalizing charge will correct these cell-to-cell imbalances and bring all the cells to the same capacity.

An equalizing charge is simply a 3-hour continuation after the standard re-charge at the chargers finish rate of 12 amps. (Minimum 3 amps per 100ah)

The best way to determine if an equalizing charge is necessary is to check the specific gravity of the battery cells. If there is more than a 0.020 specific unit variation between any two cells, the battery should be equalized.

The Batteries need to be charged at least 8 hours before any use. Preferably 12-15 hours before use will allow the battery chemistry to equalize properly before a drain is again applied to the battery

A good rule of thumb is to equalize once every 5 re-charges.

### **The Charging Process**

During the charging process, the sulfate (from the sulfuric acid)



in the battery lead plates, which is accumulated during the discharge and use process, is driven back into the electrolyte. This increases the specific gravity and brings the on-charge voltages up to 2.50-2.75V per cell depending on the battery age.

### Specific Gravity

Specific gravity measurements are based on a cell temperature of 77°F (25°C) and lower.

In order to obtain an accurate specific gravity measurement, the hydrometer reading must be adjusted based on the temperature of the electrolyte. (Battery Fluid)

Subtract 4 points of specific gravity (.004) for each 10 degrees under 77°F.

Care should at least be used to determine that each cell is close in specific gravity to each other, as an equalizing charge (See below) could be needed or a cell maybe failing.

The hydrometer must be rinsed out with clean water after each use or else it will build up a layer of dried electrolyte and give false readings.

### Temporary Storage Of Battery Pack

When the battery pack is fully charged and the electrolyte is at the proper level, the Terminator® 2100EI can be stored for up to a year. It should be stored in a cool dry, well -ventilated area away from direct sunlight. If a battery pack needs to be stored for several months or longer, a refreshing charge should be performed prior to its stored as well as at any time the specific gravity falls below 1.240. If the average storage temperature is below 68°F (20°C), check the specific gravity at least once every two months. If the average temperature is above 68°F (20°C) check it every month

Temperature effect on Specific Gravity of new Batteries  
Stored on open circuit with no drain

Temperature (Degrees Fahrenheit)	Max loss of specific Gravity (Per day)
120	.004
100	.003
80	.001
50	.0005

### Check Battery Electrolyte Weekly

Every cell should be inspected to be sure that the electrolyte level is above the moss guard (top of lead plates). If the electrolyte is slightly below the moss guard in any cell, transferring a small amount of electrolyte from another cell that has a higher level with a syringe or hydrometer can raise it.

If a large amount of electrolyte is needed to raise the level, first check the catchments tray for any battery electrolyte. If some is found due to a leaking cell call a trained battery technician from an authorized repair facility. Call your Innovatech representative if no repair facility is available. Do not attempt to charge or use the Terminator® 2100EI while there is a leak in the battery pack. If no leak is found simply add a little Distilled Water to the cell, being careful not to overfull the cell as it will spill out when the Terminator is raised on it's scrapper blade and moving. A little water is lost each time the battery pack is charged, water is given off as hydrogen (H<sub>2</sub>) and oxygen (O<sub>2</sub>). This is the source of the explosive gasses that are released during charging.

Each time a battery is charged and then discharged this is called a cycle. An average battery will last from 1,500 to 1,800 cycles, or 5 to 6 years. Actual battery life will depend on type of battery, the severity of use, and how well the battery was maintained while in service.

To obtain maximum service life from your battery pack, care should be taken to not operate the battery pack over 115° F (46°C) as well as not to run the battery pack below 80% of nominal voltage. (The controller onboard the Terminator® 2100E

will shut the power down if this limit is reached). Frequent overcharging or equalizing will shorten the battery life.

## **First Aid**

### **First Aid for Acid Splashes**

**Eyes:** Flush immediately with gently running water for at least 15 minutes, then see a doctor as quickly as possible. For contact lens wearers, remove the lens before the eyes are flushed. A buffering or neutralizing agent should not be used in the eyes without the approval of medical or safety personnel.

**Skin:** Wash affected areas under running water and apply a chemical burn treatment.

Severe burns require immediate medical attention.

**Clothing:** If large areas of clothing have been splashed or soaked, the clothing must be removed and the acid must be neutralized with a baking soda or soda ash solution, and then rinsed under running water. If the clothing is rinsed quickly enough, the chances of damage to the material are lessened. Acid-resistant boots should always be checked before wearing, for any acid puddles that may have formed inside the boot.

### **Eye Wash And Emergency Shower Facilities**

Emergency eyewash and acid neutralization facilities should be located in the immediate work area for easy access. The three most popular types of eyewash and acid neutralizing equipment are the chemical burn stations, deluge shower and eye wash fountains.

1. A chemical burn station is the most commonly used type in small battery charging and repair areas. The station consists of a wall mounted plastic squeeze bottle that contains a buffer-

ing solution for treating acid burns on skin, eyes and clothing. This inexpensive equipment is practical for personnel protection while working on the Terminator® 2100EI battery pack. The spill kit and a source of running water is needed for large spills on the floor.

2. A Deluge Shower should be used where high specific gravity acid (above 1.400) is handled. The Terminator® 2100EI does not use this high of a specific gravity concentration. This type of wash station is only really needed at a battery repair center.

An eye wash fountain is permanently hooked up to a water supply and is usually wall mounted. This is recommended equipment if possible.

## **Maintenance Procedures**

- 1.) Grease Caster Wheel at three fittings every 30 hours.
- 2.) Check Hydraulic Oil Once a month. Change every 18 months with NUTO H 46 or ISO 46 or if fluid is overheated 200°F or higher.
- 3.) Change hydraulic filter every 60 hours.
- 4.) Check water level once a week in batteries.
- 5.) Clean Caster Wheel and Back Tires with wire wheel when necessary.
- 6.) Look for leaks, find and tighten fittings – do not over tighten fittings.
- 7.) Check all hoses and clamps once a week.
- 8.) Inspect rear tires and lug bolts. Tighten lug bolts as needed to 70-foot pounds torque.
- 9.) Check wheel hub every 60 hours of operation. Wheel hub pack nut should be torqued from 310 to 350 foot pounds (ft.-lbs).

## Warranty

Innovatech warrants to the original buyer, for a period of one (1) year or 300 operating hours (whichever comes first) from the date of delivery, that Equipment is free from defects in materials and workmanship and that the Equipment conforms to the operating specifications supplied with the Equipment. The foregoing warranty is subject to proper operation and maintenance of the Equipment in accordance with the operating instruction and manual supplied to Buyer with the Equipment.

Warranty claims shall be made by Buyer in writing. Innovatech's sole obligation under the foregoing warranty, where it appears to Innovatech's satisfaction that the defect was present at the time of delivery, is at Innovatech's sole option, to repair, replace or correct any such defect.

EXCEPT AS STATED ABOVE THERE ARE NO WARRANTIES, EXPRESS OR IMPLIED. INNOVATECH EXPRESSLY DISCLAIMS ANY WARRANTY, EXPRESS OR IMPLIED, THAT EQUIPMENT SOLD HEREUNDER IS OF MERCHANTABLE QUALITY OR THAT IT CAN BE USED FOR OR IS FIT FOR ANY PARTICULAR PURPOSE. ANY DESCRIPTION OF THE EQUIPMENT IN THIS AGREEMENT OR IN MANUALS, BROCHURES OR LITERATURE AND ANY USE OF ANY SAMPLE, MODEL OR PROTOTYPE OF THE EQUIPMENT IS FOR THE SOLE PURPOSE OF IDENTIFYING OR ILLUSTRATING THE EQUIPMENT, IS NOT PART OF THE BASIS OF THE AGREEMENT BETWEEN INNOVATECH AND BUYER, AND DOES NOT CONSTITUTE A WARRANTY THAT THE EQUIPMENT, AS SUPPLIED, WILL CONFORM TO ANY DESCRIPTION OR TO ANY SAMPLE, MODEL OR PROTOTYPE. INNOVATECH DISCLAIMS ANY WARRANTY RESPECTING OPERATING CAPACITY OR CAPABILITY OF THE EQUIPMENT OR THE ABILITY OF THE EQUIPMENT TO MEET ANY PARTICULAR NEEDS OF THE BUYER. THE EQUIPMENT IS POWERED TO OPERATE AS STATED IN THE OPERATING SPECIFICATIONS SUPPLIED WITH THE EQUIPMENT BUT IT IS UNDERSTOOD AND AGREED TO BUY BUYER THAT ACTUAL OPERATING CAPABILITIES VARY UNDER DIFFERENT OPERATING CONDITIONS FOR WHICH INNOVATECH CAN ASSUME NO RESPONSIBILITY.

BUYER'S EXCLUSIVE REMEDY FOR CLAIMS ARISING UNDER THIS AGREEMENT SHALL BE FOR REPAIR OR, AT INNOVATECH'S SOLE OPTION, REPLACEMENT OF ANY ITEM OF DEFECTIVE EQUIPMENT. INNOVATECH'S LIABILITY FOR ANY LOSSES OR DAMAGE, WHETHER ON ACCOUNT OF NEGLIGENCE, BREACH, WARRANTY OR OTHERWISE SHALL IN NO EVENT EXCEED THE PURCHASE PRICE OF THE PARTICULAR ITEM OF EQUIPMENT WITH RESPECT TO WHICH SUCH LOSSES OR DAMAGE OCCURRED. IN NO EVENT WILL INNOVATECH BE LIABLE FOR ANY DAMAGES CAUSED BY BUYER'S FAILURE TO PERFORM BUYER'S RESPONSIBILITIES, OR FOR ANY LOST PROFITS, LOST PRODUCTION, LOSS OF ANTICIPATED PROFITS OF OTHER INCIDENTAL OR CONSEQUENTIAL DAMAGES, EVEN IF INNOVATECH HAS BEEN ADVISED OF THE POSSIBILITY OF SUCH DAMAGES. IN NO EVENT WILL INNOVATECH BE LIABLE FOR ANY DAMAGES RESULTING FROM ANY CLAIM AGAINST BUYER BY ANY OTHER PARTY.

### FACTORY SERVICE

A warranty will not be valid unless a written claim authorization comes with returned parts. Innovatech will not provide for any shipping costs for items returned for repair. To obtain warranty repairs, buyer must prepay shipment and return all warranty parts to Innovatech. Damage occurring during shipment is deemed the responsibility of the carrier and claims should be made directly with such carrier.

It will be the customer's responsibility to pay for any non-warranty replacement parts plus the current hourly labor rates for any work done on any machine or part. Service is available upon request; call Innovatech for current labor rates.

## Parts Diagrams

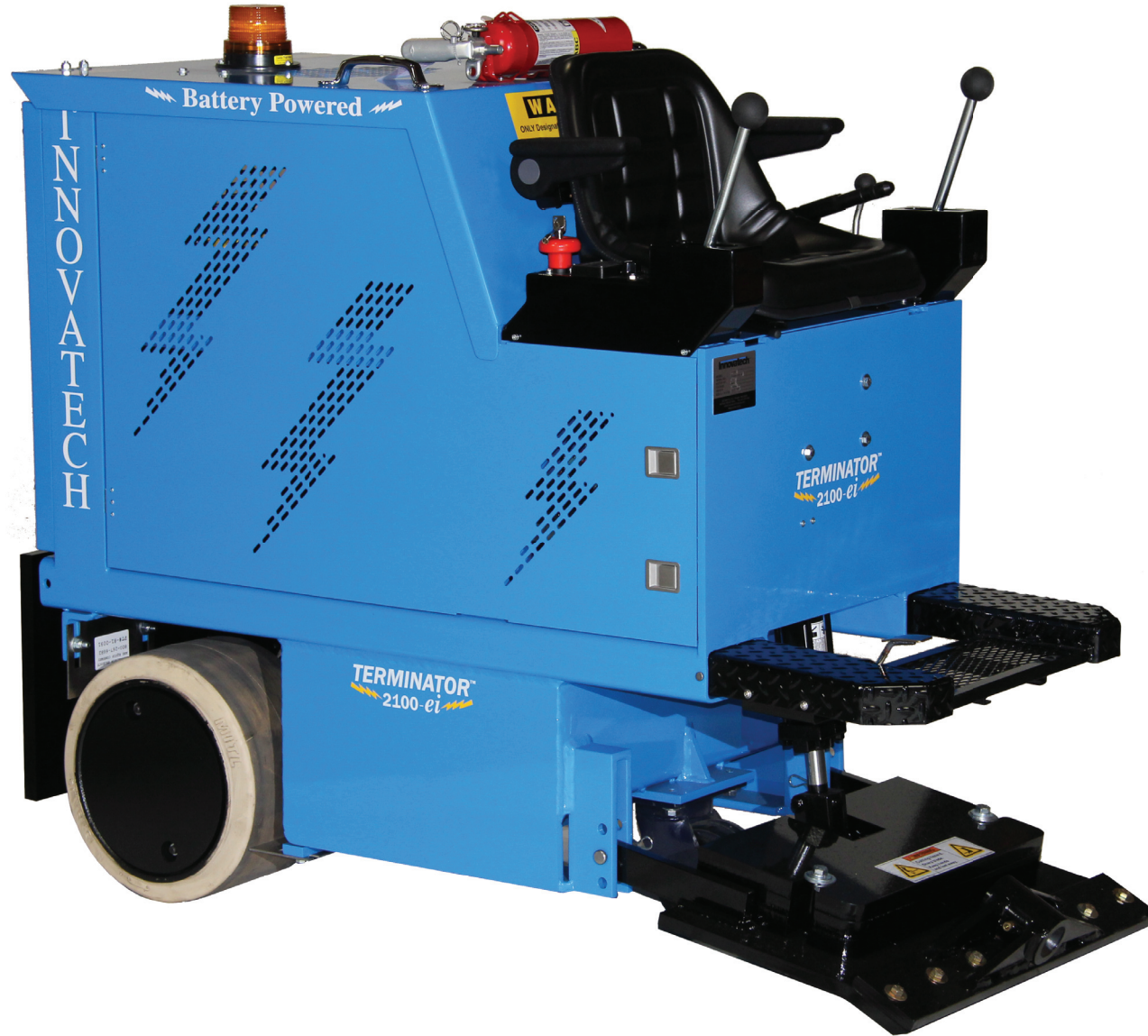

Item No.	Part Number	Description	Qty.
8	96-0251	Foot Rest Assy	1
9	11-0041	Split Lock Washer, 1/2"	3
12	11-0296	Hex Head Cap Screw, 1/2"-13 x 1-1/2"	2
17	96-0219	Jaw Assembly	1
19	52-0161	Seat Support Panel	1
20	11-0309	Thumb Screw, 1/4"-20 x 5/8	4
24	11-0045	Clevis Pin, 5/8 dia. x 3 L	2
25	11-0052	Cotter Pin	2
31	13-0049	Seat Assy (w/ sliding tracks)	1
32	11-0217	Screw, Button Head Socket Cap, 5/16"-18 x 3/4"	4
33	11-0025	Nut (Nylon-insert), 5/16"-18	4
34	11-0033	Flat washer, 1/4"	4

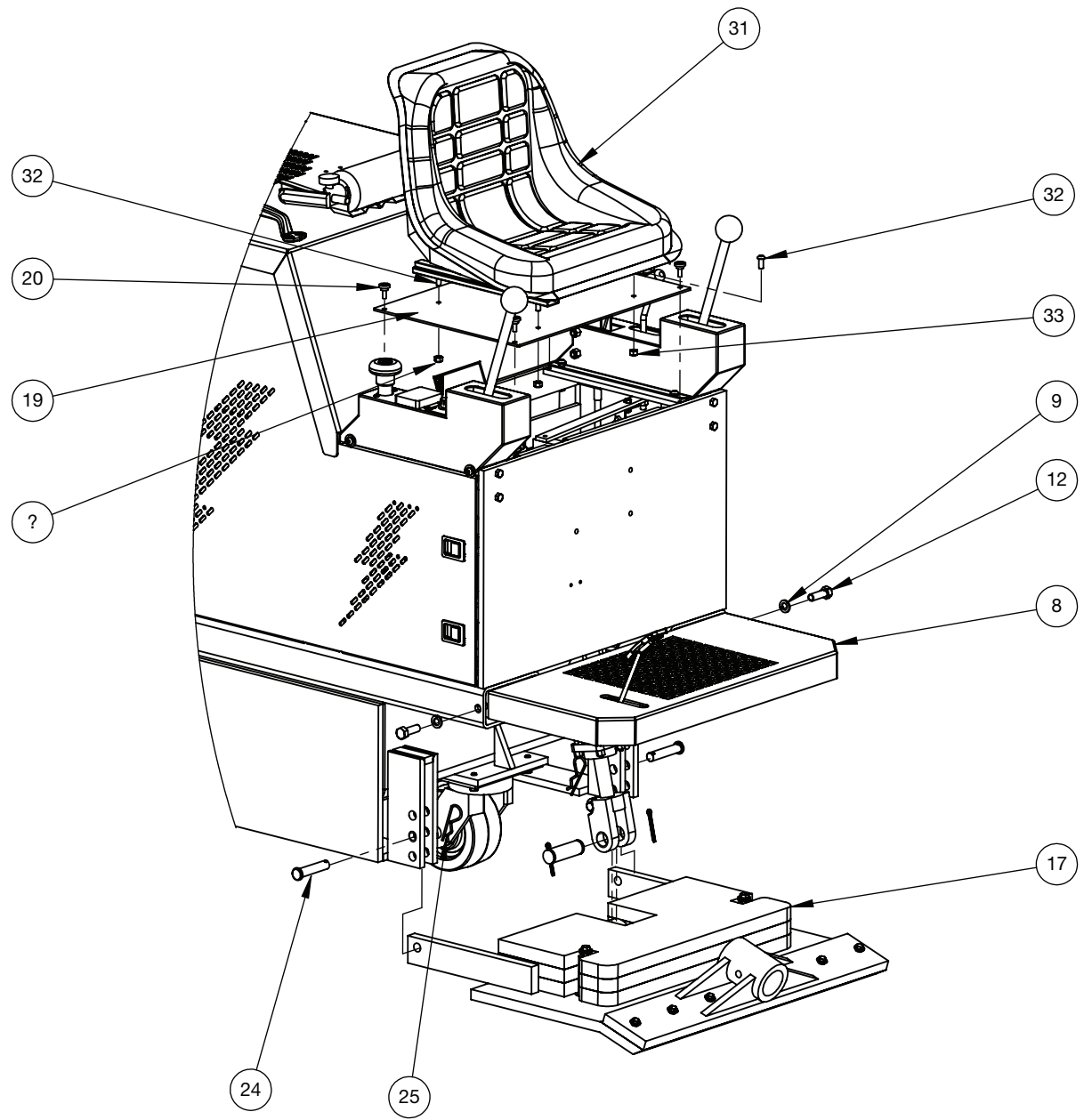

Item No.	Part Number	Description	Qty.
10	11-0069	Steel Split Lock Washer, 1/4"	4
13	11-0133	Steel Hex Head Cap Screw, 1/4"-20x3/4"	4
17	52-0157	Hydraulic Shield Panel	1
31	11-0033	Flat Washer, 1/4"	4

\*These items not included on Serial Numbers T2100-002-IB through T2100-011-IB



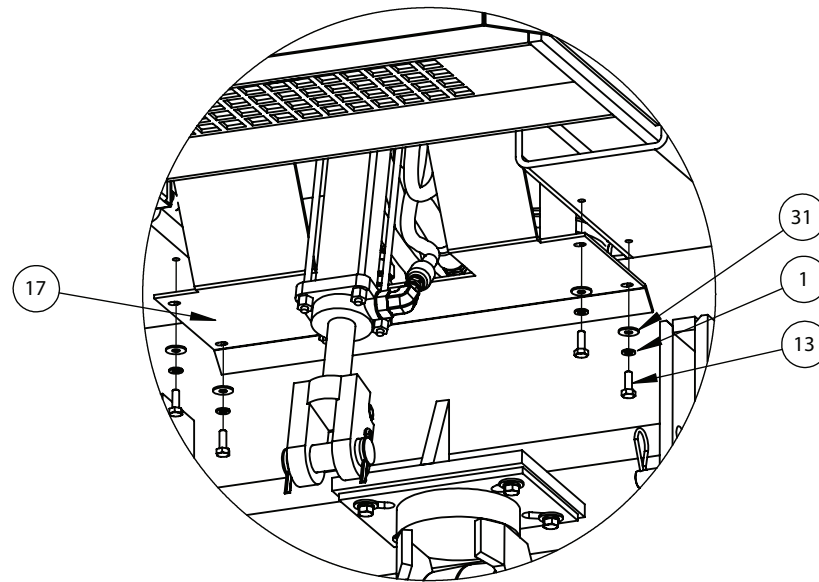

Item No.	Part Number	Description	Qty.
6	96-0210	Door Assy - Left	1
7	96-0211	Door Assy - Right	1
9	11-0041	Split Lock Washer, 1/2"	3
11	11-0040	Steel USS Flat Washer, 5/16"	10
14	11-0175	Steel Hex Head Cap Screw, GR5: 5/16"-18x2"	4
15	11-0118	Hex Head Cap Screw, GR5: 5/16"-18x3/4"	6
16	11-0012	Steel Hex Head Cap Screw, GR5: 1/2"-13x2"	1
21	96-0008	Top Cover Assembly	1
22	53-0064	Rear Cover	1
26	11-0034	Steel USS Flat Washer, 5/16"	10
27	11-0230	Steel USS Flat Washer, 1/2"	1
28	53-0067	Rear Weight unit	1
29	71-0014	Battery Pack, T-2100EI	1
30	51-0349	Battery Tray Stop	1
34	11-0033	Flat Washer, 1/4"	4

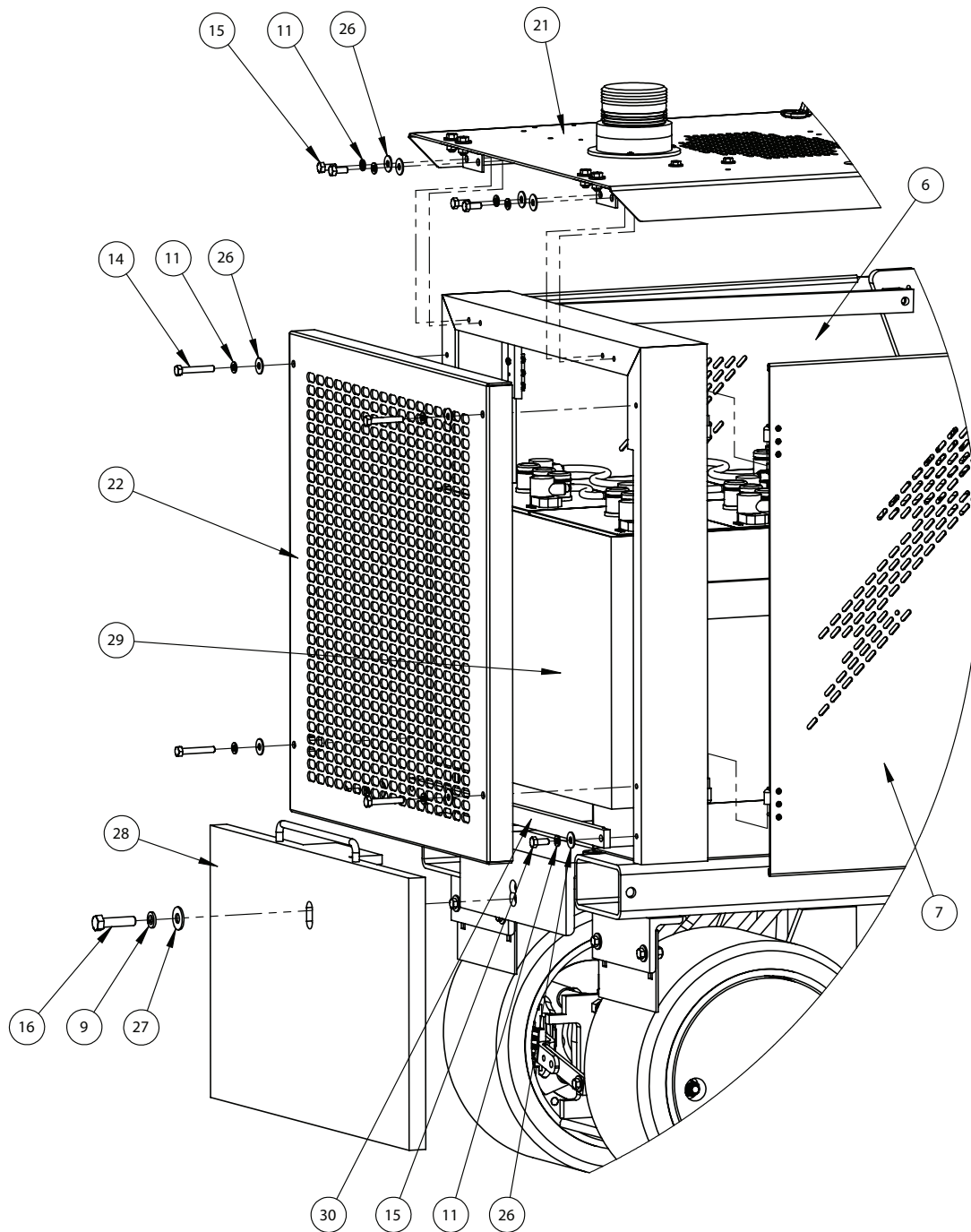

Item No.	Part Number	Description	Qty.
1	53-0242	Frame Assembly	1
2	33-0002	Wheel Motor, Left Side	1
3	33-0003	Wheel Motor, Right Side	1
4	13-0008	Caster Wheel Assembly	1
5	13-0022	Brake Mounting Bracket	2
10	13-0020	Left Brake Caliper	1
11	13-0021	Right Brake Caliper	1
12	53-0208	Wheel and Tire Assembly	2
13	70-0016	Wheel Hub with Brake	2
14	81-0091	Wheel Scraper Blade, 2 Slot, 7.5" x 4.5"	4
15	51-0609	Brake Linkage	1
16	31-0053	90 deg Hydraulic Fitting	4
18	13-0019	Brake Actuator Pin	1
19	11-0035	Steel USS Flat Washer, 3/8"ID, ZP	18
20	11-0230	Steel Flat Washer, 1/2" ZP	18
21	11-0194	Hex Bolt, 3/8"-16 x 1.5", ZP	6
22	11-0228	Hex Bolt, 1/2"-13 x 5", ZP	4
23	11-0013	Hex Bolt, 1/2"-13 x 3", ZP	4
24	11-0007	Hex Bolt, 3/8"-16 x 5", ZP	4
25	11-0177	Hex Bolt, 1/2"-13 x 1", ZP	4
26	11-0133	Steel Hex Head Cap Screw, Gr5, 1/4"-20 x 3/4"L, ZP	1
27	11-0029	Steel Nylon-Insert Lock Nut, 1/2"-20, ZP	14
28	11-0026	Steel Nylon-Insert Lock Nut, 3/8"-16 ZP	7
29	11-0028	Steel Nylon-Insert Lock Nut, 1/2"-13, ZP	8
30	11-0187	Double Ended Stud, 1/2"-13 x 2.5"	4
31	53-0212	Wheel Weights, 2"	2
32	11-0041	Steel Split Lock Washer, 1/2", ZP	8
33	11-0129	Steel Split Lock Washer, 3/8", ZP	4

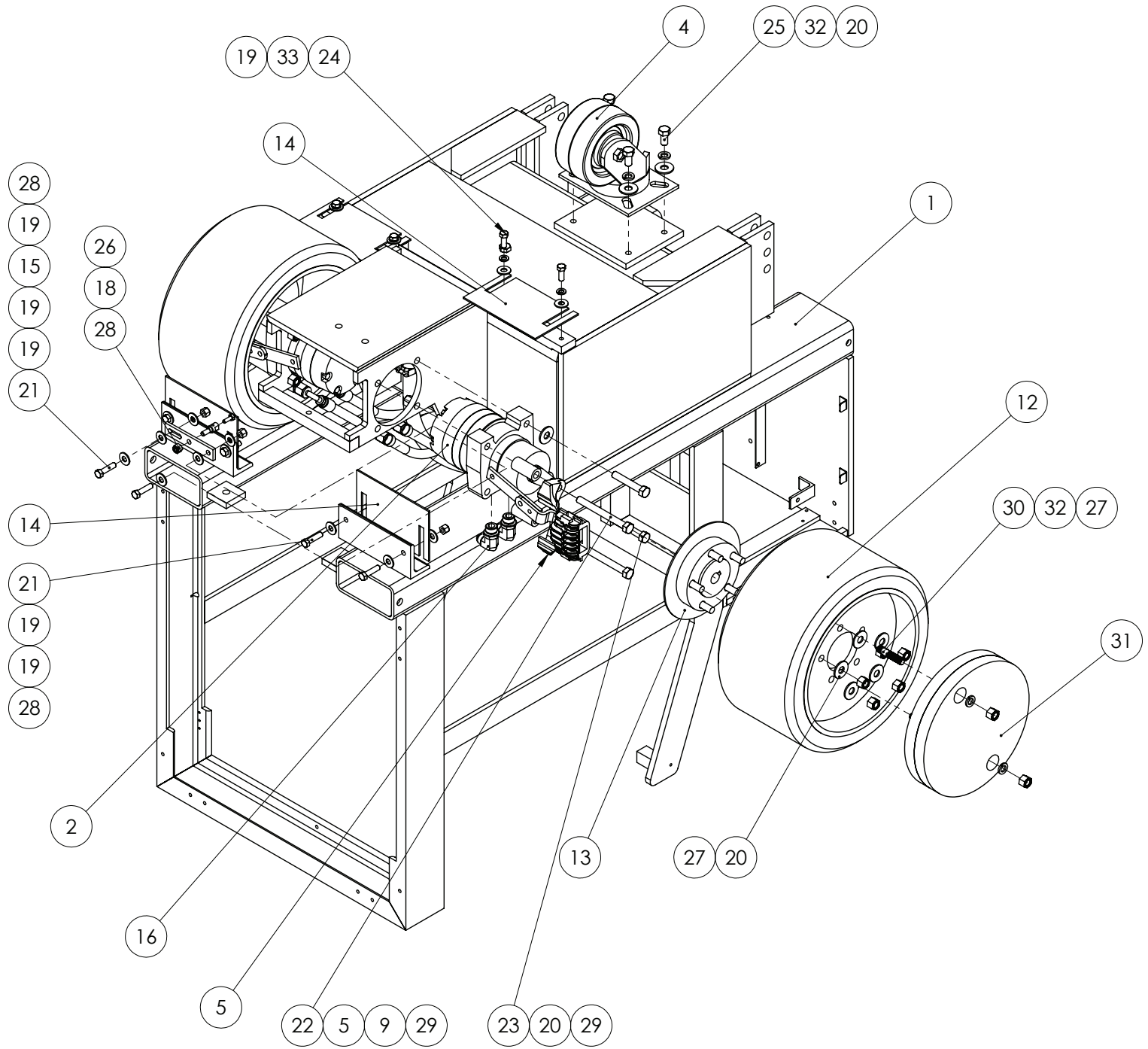

Item No.	Part Number	Description	Qty.
6	35-0023	Hydraulic Tank Strainer	1
7	35-0024	Hose Clamp	1
8	35-0006	90 Deg Street "L", 1" NPT	1
17	31-0055	Hydraulic Fitting, Hose Barb to 1"NPT	1
34	31-0175	Hose Assembly, Tank Suction	1
35	31-0015	Hose Assembly, Left Front Wheel Motor Fitting to Top Left Valve Fitting	1
36	31-0174	Hydraulic Hose Assembly, Left Front Wheel Motor Fitting to Bottom Left Valve Fitting	1
37	31-0176	Hydraulic Hose, Right Wheel Motor Front Fitting to Valve Right Bottom	1
38	31-0007	Hydraulic Hose, Right Wheel Motor Rear Fitting to Valve Top Right Fitting	1

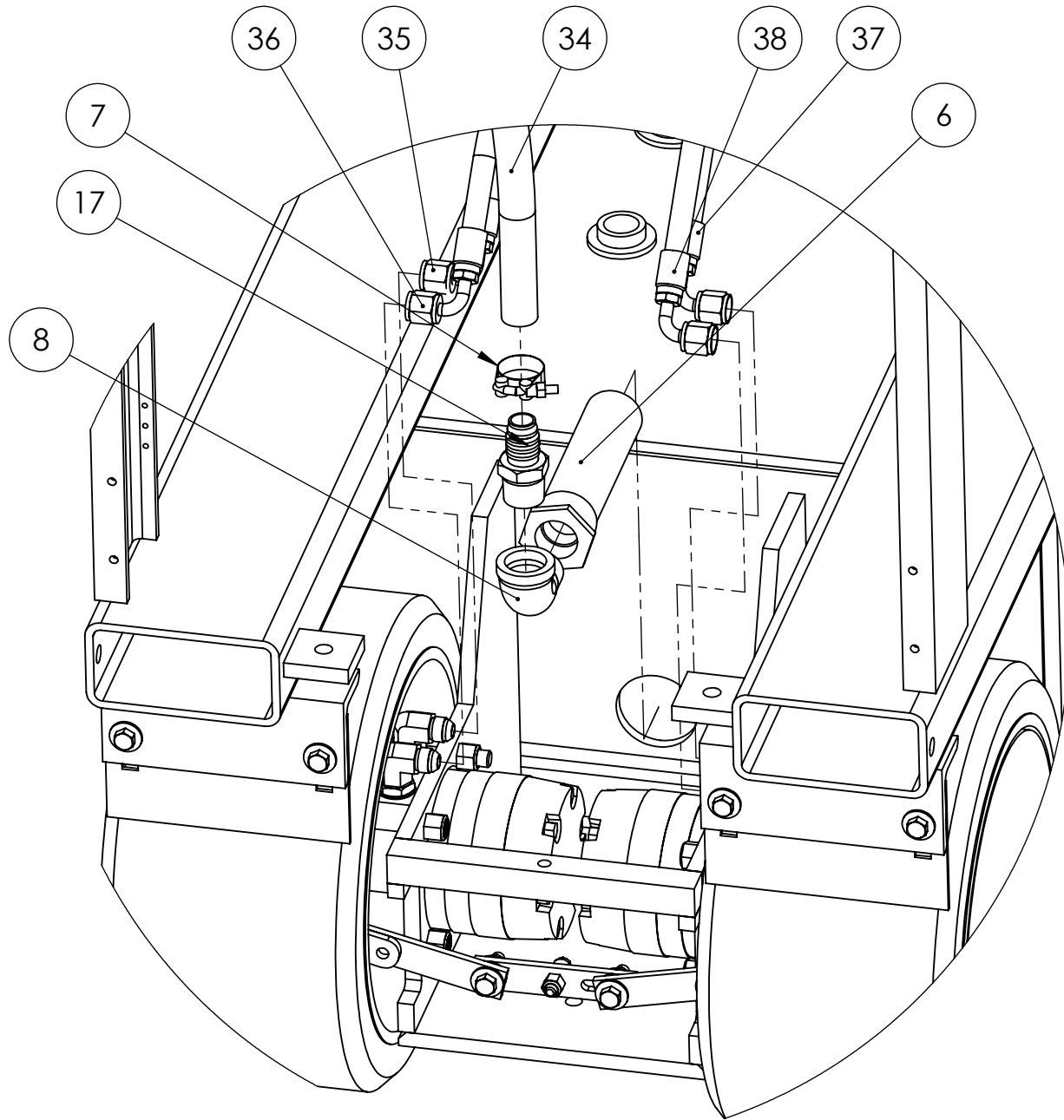

Item No.	Part Number	Description	Qty.
2	96-0238	T-2100EI Wheel Assembly	1
5	11-0034	Steel Flat Washer, 5/16", ZP	13
9	11-0025	Steel Nylon-Insert Lock Nut, 5/16"-18 ZP	7
10	35-0036	Hydraulic Oil Filter*	1
11	35-0004	Pipe Adapter, 1" NPT x 6" L	1
12	35-0021	Hydraulic Tank Breather Cap	1
13	53-0044	Dip Stick Assembly	1
14	11-0069	Steel Split Lock Washer, 1/4", ZP	2
15	11-0133	Steel Hex Head Cap Screw, Gr5, 1/4"-20 x 3/4"L, ZP	2
17	31-0046	Hydraulic Fitting, #6JIC to #6SAE	2
18	31-0052	Hydraulic Fitting, 90 Deg, #10JIC to #12SAE	1
19	31-0056	Hydraulic Fitting, 90 Deg, #6JIC to #6SAE	2
20	31-0024	Hydraulic Fitting, #4JIC to #6SAE	1
22	35-0042	Hydraulic control valve (modified)	1
23	31-0045	Hydraulic Fitting, #8SAE to 1/4"NPTF	1
24	31-0047	Hydraulic Fitting #12JIC to 1/2" Male NPT	1
25	31-0048	Hydraulic Fitting, 90 Deg, #10 JIC to #8 SAE	2
26	31-0051	Hydraulic Fitting, 90 Deg, #12 JIC to #12 SAE	1
28	22-0007	Oil Temperature Switch	1
29	35-0022	Tank Diffuser	1
30	31-0066	Hydraulic Hose, Valve to Filter	1
31	31-0012	Hydraulic Hose, Filter to Tank	1
32	31-0005	Hydraulic Hose, Pump to Valve	1
33	31-0022	Flow Reducer	1
34	31-0008	Hydraulic Hose, Valve Top Center to Cylinder Bottom	1
35	31-0018	Hydraulic Hose, Valve Bottom Center to Cylinder Top Fitting	1
36	11-0005	Hex Bolt, 5/16"-18 x 3", ZP	3

\*Serial Numbers T2100-002-IB through T2100-011-IB use oil filter 32-0007 replacement element 32-0008



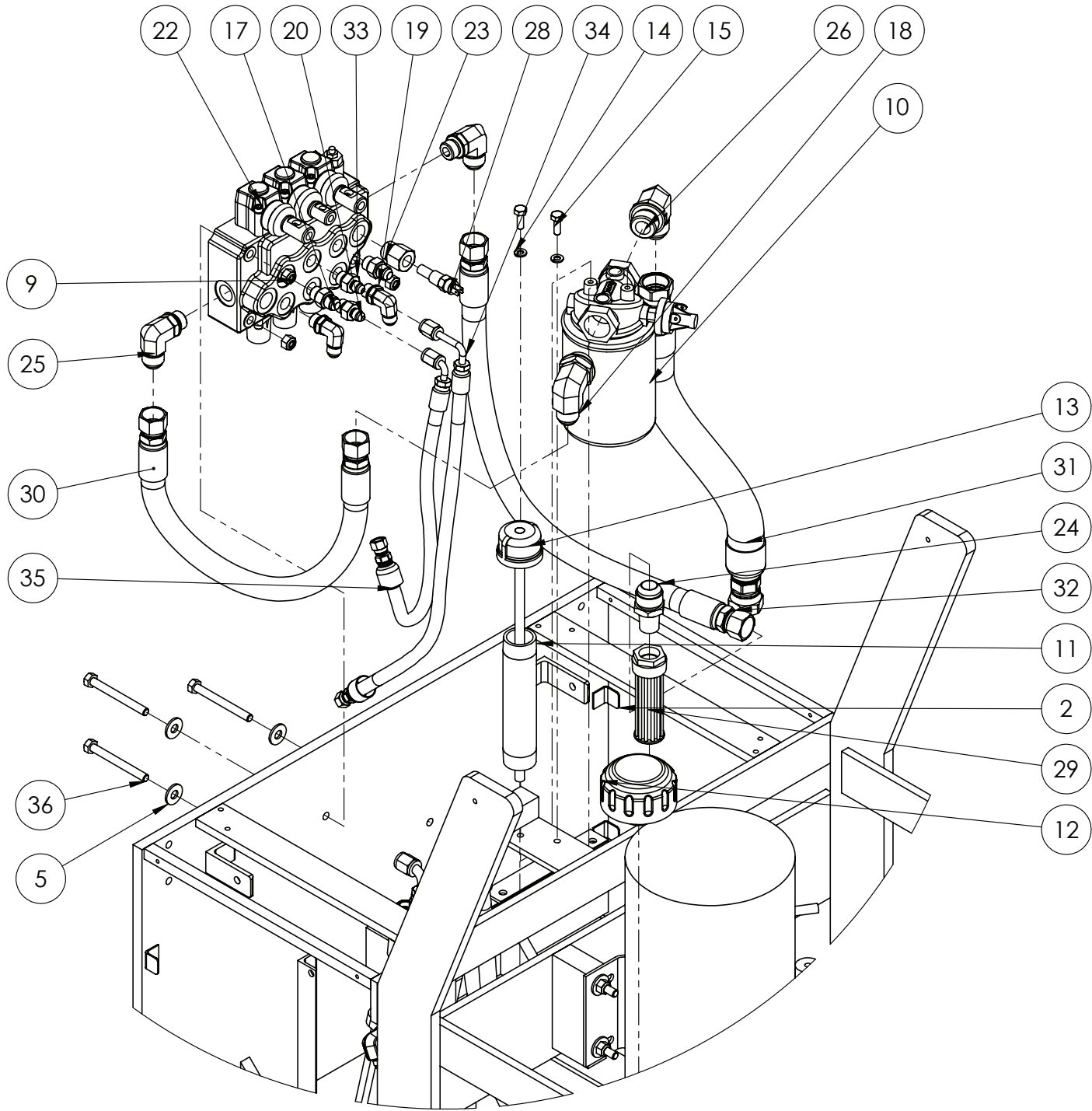

Item No.	Part Number	Description	Qty.
3	31-0020	Hydraulic Pump	1
4	23-0002	Electric Motor	1
5	11-0034	Steel Flat Washer, 5/16", ZP	13
6	11-0129	Steel Split Lock Washer, 3/8", ZP	2
7	11-0295-20	Steel Hex Head Cap Screw, 3/8"-24 x 1-1/4"L ZP	2
8	11-0006	Steel Hex Bolt, 5/16"-18 x 3-1/2", ZP	4
9	11-0025	Steel Nylon-Insert Lock Nut, 5/16"-18 ZP	7
16	31-0038	Hydraulic Fitting, 90 Deg, #10JIC to #10SAE	1
27	31-0072	Hydraulic Fitting, #16 JIC to #12 SAE	1

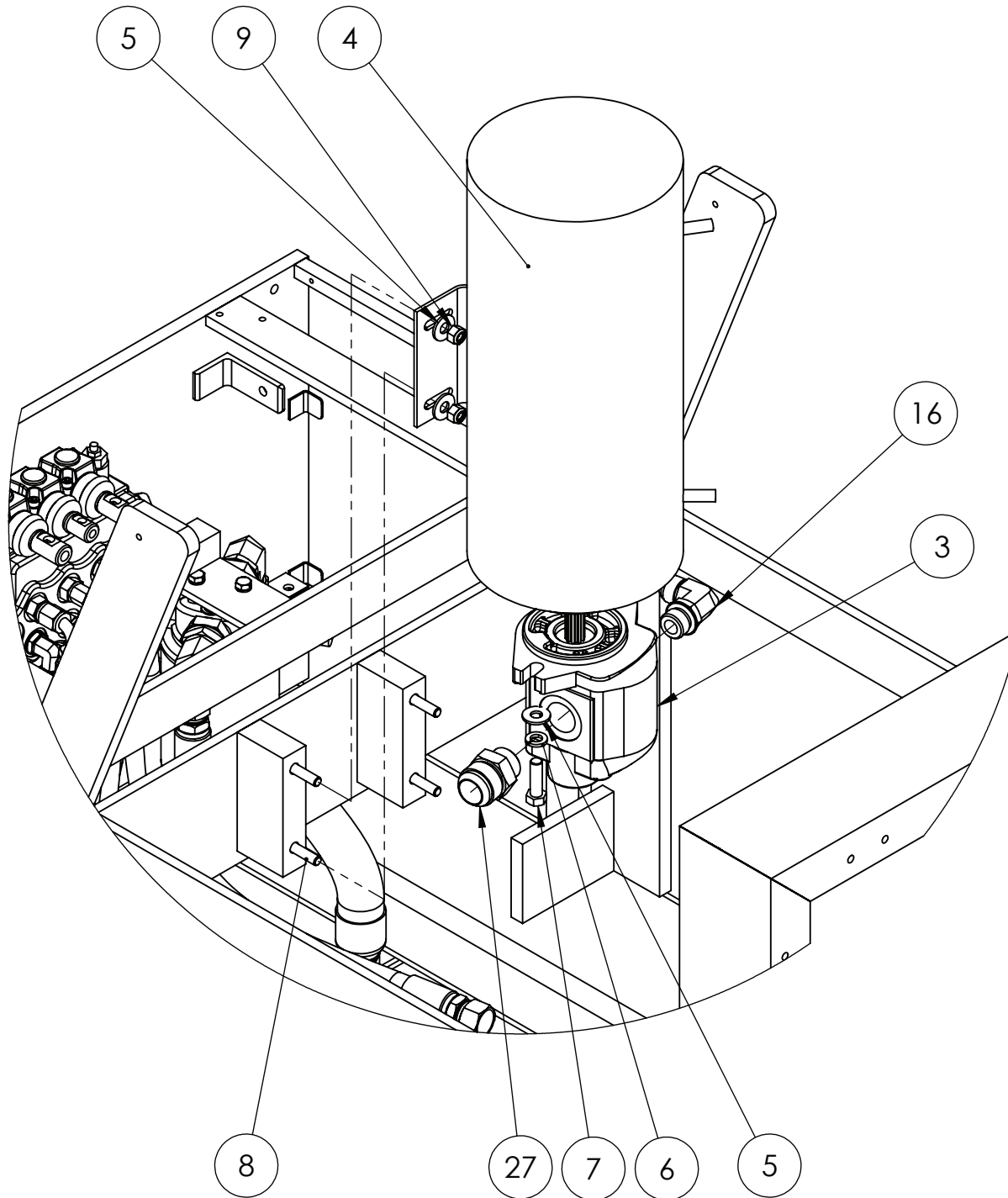

Item No.	Part Number	Description	Qty.
1	34-0008	Hydraulic Cylinder, 2" Bore, 6" Stroke	1
21	31-0043	Hydraulic Fitting, 90 Deg, #4JIC to #8SAE	2
34	31-0008	Hydraulic Hose, Valve Top Center to Cylinder Bottom	1
35	31-0018	Hydraulic Hose, Valve Bottom Center to Cylinder Top Fitting	1

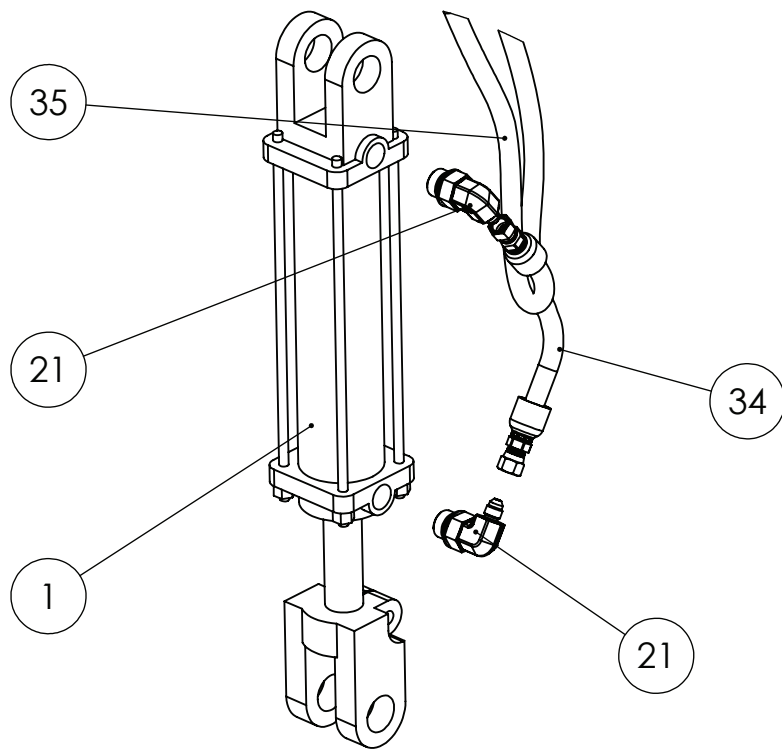

Item No.	Part Number	Description	Qty.
1	51-0746	Heatsink Plate	1
2	23-0032	Power Control Module	1
3	25-0032	Fuse Block, 6 Gang, ATO Style	1
4	25-0053	Fuse (5 Amp)	6
5	11-0233	Screw, Pan Head Phillips, #10-24 x 1"L	4
6	11-0133	Screw, Hex Head, 1/4"-20 x 3/4"L	4
7	11-0069	Steel Split Lock Washer, 1/4"	4

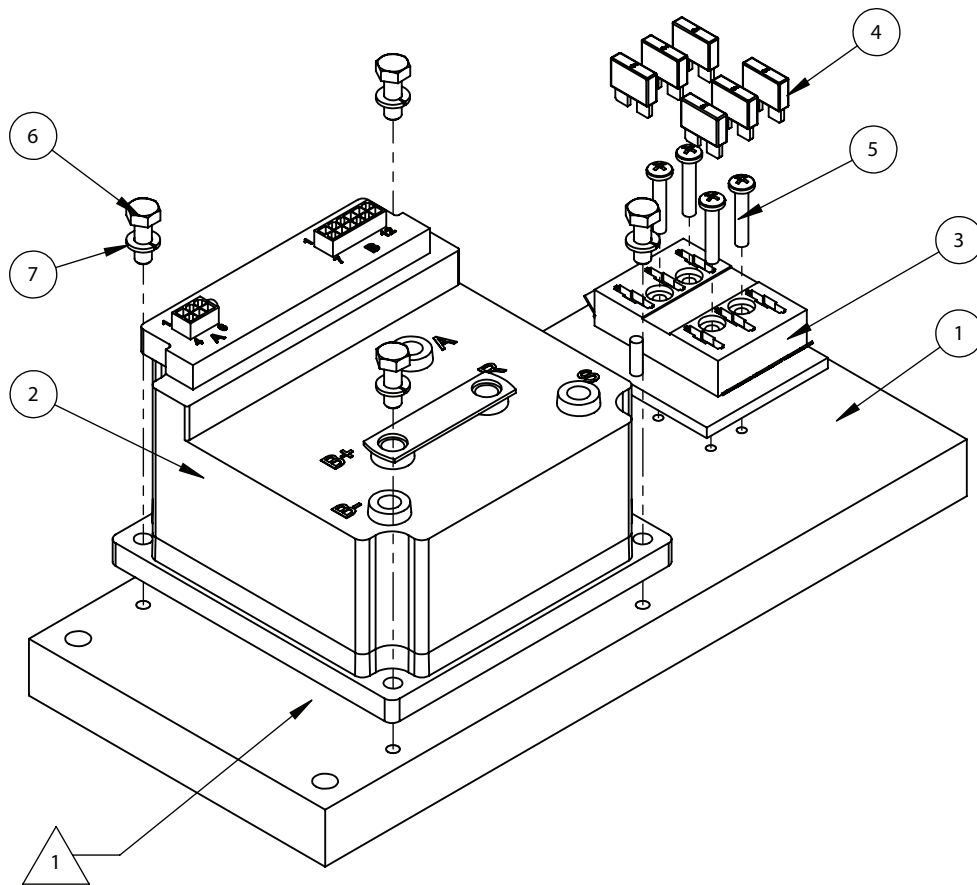

Notes:

1. Use Thermal Transfer compound (Chemplex 1381 or Equiv.) between Heat Sink Plate and Power Control Module

Item No.	Part Number	Description	Qty.
1	53-0241	Battery Tray	1
2	23-0013	Battery, 6VDC Deep Cycle	8
3	25-0010	Battery Flip Cap	24
4	24-0143	Battery Pack Pig Tail	1
5	24-0036	Battery Pack Interconnect Wire, 5"	1
6	24-0035	Battery Pack Interconnect Wire, 10"	2
7	24-0034	Battery Pack Interconnect Wire, 10.5"	1
8	24-0033	Battery Pack Interconnect Wire, 10.75"	2
9	24-0032	Battery Interconnect Wire, 13.5"	1
10	25-0008	Black Battery Lug Cover	8
11	25-0007	Battery Lug Cap, Red	8
12	11-0055	Steel Hex Cap Screw, 1/4"-20 x 1.5"	2
13	11-0024	Steel Nylon-Insert Lock Nut, 1/4"-20 ZP	4
14	23-0009	Fuse Block, 300 Amp Max	1
15	23-0010	Fuse, 275A	1
16	11-0133	Steel Hex Head Cap Screw, Gr5, 1/4"-20 x 3/4"L, ZP	2
17	24-0140	Battery Pack to Fuse Interconnect Wire	1
18	11-0132	Steel Hex Head Cap Screw, Gr5: 5/16-18 x 1	16
19	11-0067	Steel Hex Nut, 5/16"-18, ZP	18



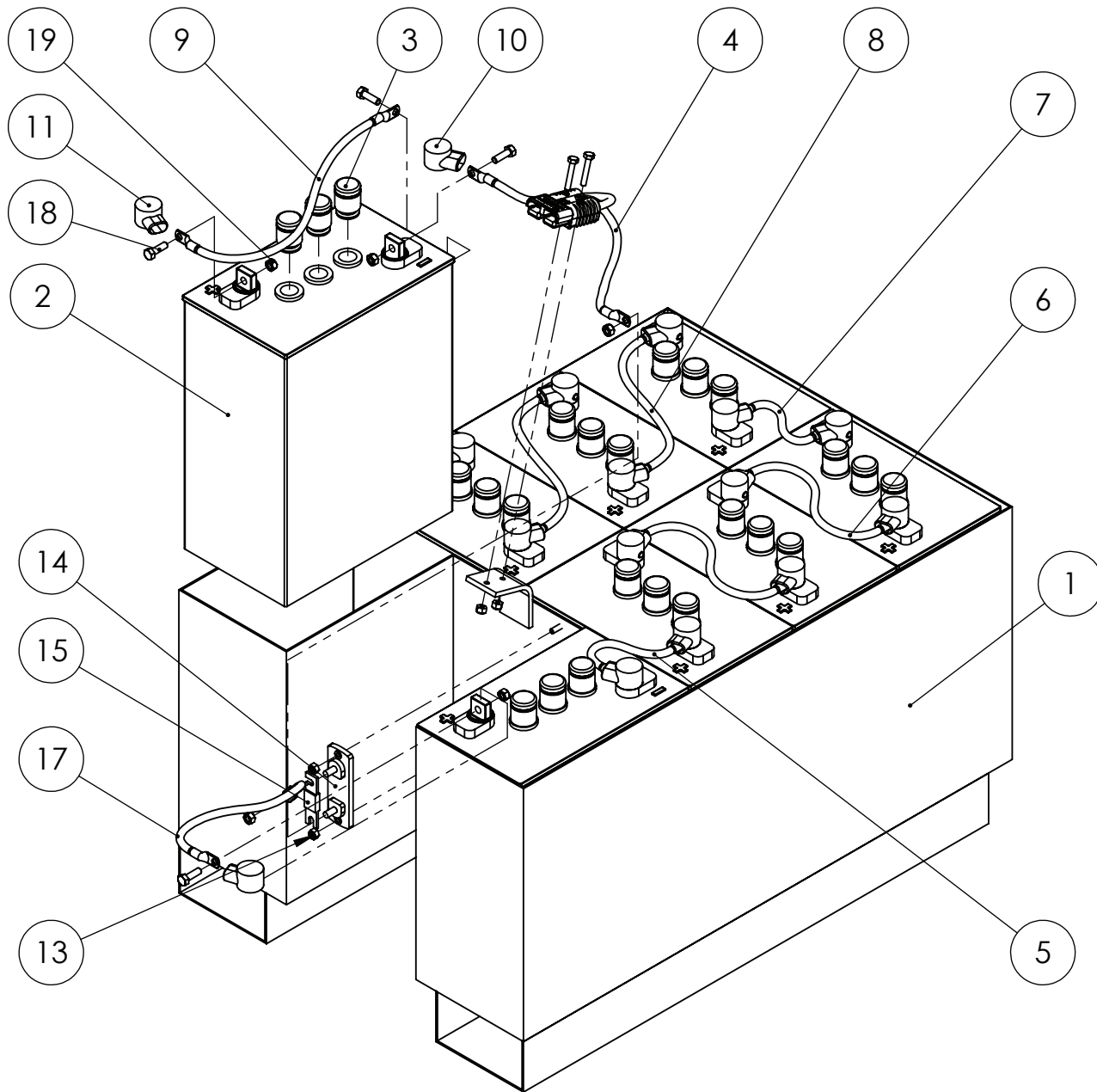

Item No.	Part Number	Description	Qty.
1	53-0035	Front Jaw Assembly	1
2	53-0162	T-2000 Standard Front Weight	3
3	11-0036	Flat Washer, 7/16", ZP	6
4	11-0014	Hex Bolt, Gr5, 1/2"-13 x 4.5", ZP	2
5	11-0010	Hex Head Cap Screw, Gr 8, 7/16"-20 x 1.75", ZP	6
6	11-0041	Steel Flat Washer, 1/2"	2
7	11-0148	Steel Flat Washer, 5/8"	2
8	11-0041	Steel Split Lock Washer, 1/2", ZP	2
9	81-0022	Swivel Head Reciever	1

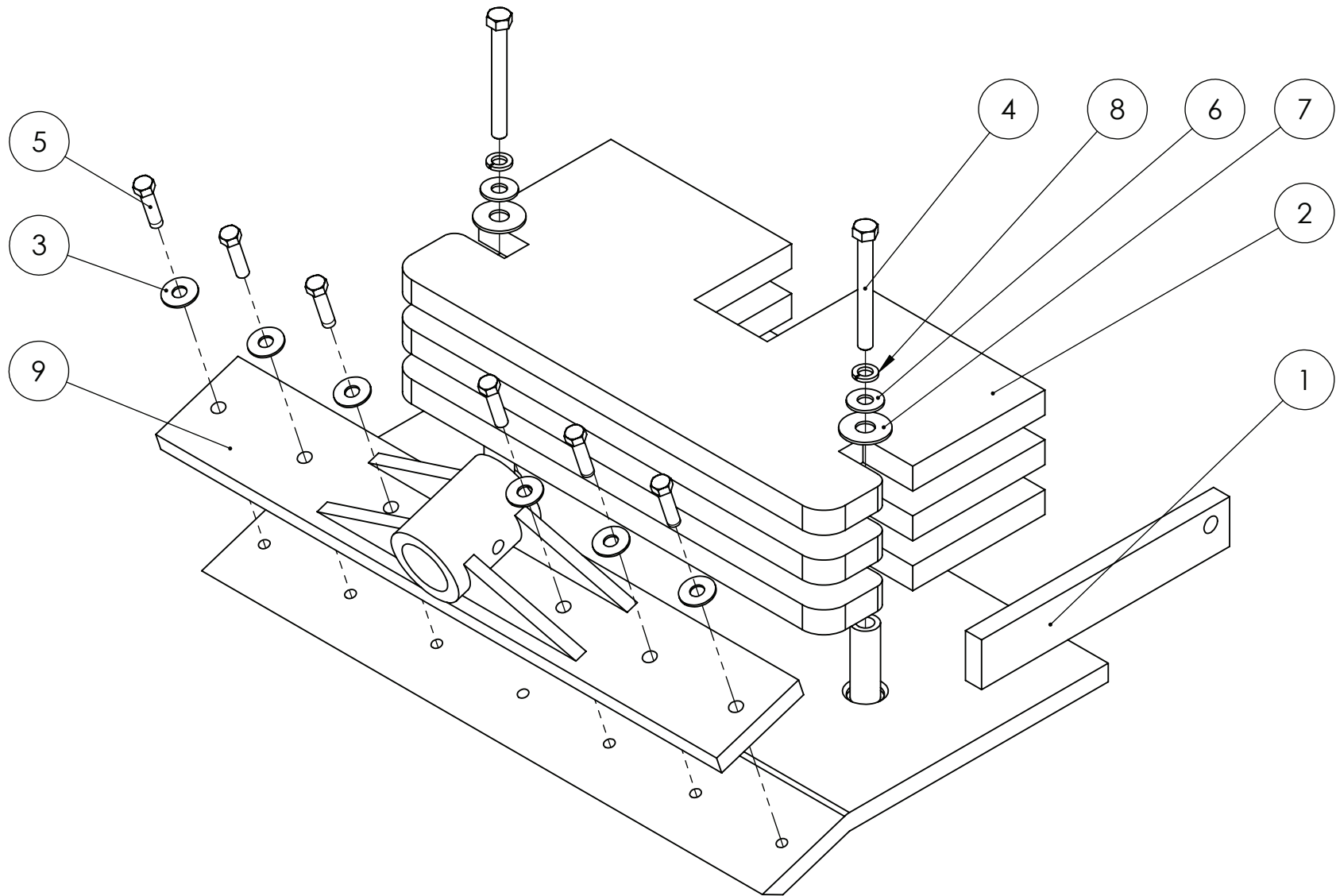

Item No.	Part Number	Description	Qty.
1	96-0239	Joystick mechanism (wheels control)	2
2	96-0240	Joystick mechanism (jaw control)	1
3	11-0132	Screw, hex head, 5/16-18 x 1	4
4	11-0025	Nut (Nyloc insert), 5/16-18	4
5	12-0024	Screw, hex head, M10-1.5 x 30 (1.18"),	2
6	11-0162	Washer (Belleville) 3/8" / M10	2
7	11-0305	Screw, 5/16" dia. x 1" L shoulder	1
8	11-0024	Nut (Nyloc insert), 1/4-20	2
9	12-0025	Screw, hex head, M8-1.25 x 30 (1.18"),	1
10	11-0040	Washer (lock), 5/16	1
11	11-0306	Screw, socket head shoulder, 5/16" dia. x 3/8" L shoulder	1

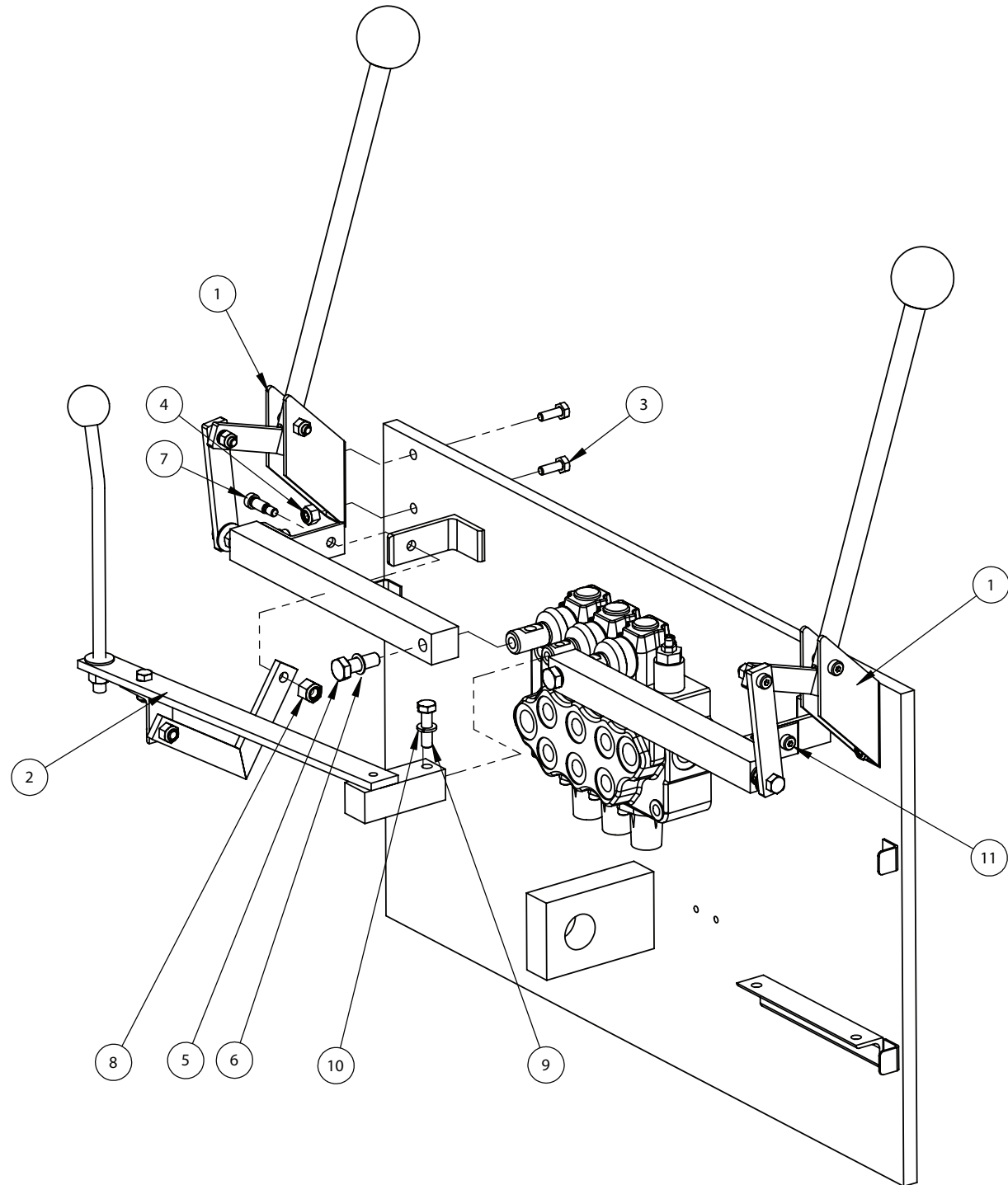

Item No.	Part Number	Description	Qty.
1	11-0134	Screw, Button Head Socket Cap Screw, #10-24x1/2, ZP	2
2	11-0026	Steel Nylon-Insert Lock Nut, 3/8"-16 ZP	2
3	52-0154	Console (left side)	1
4	13-0050	Brake lever	1
5	13-0023	Brake cable	1
6	13-0027	Clevis	1
7	11-0099	Steel Hex Head Cap Screw, GR8: 3/8"-16x3-1/2"	2
8	11-0212	Screw, Button Head Socket Cap Screw, 1/4"-20x1/2", 18-8 SS	2
9	11-0072	Split Lock Washer, #10	2
10	11-0069	Steel Split Lock Washer, 1/4"	2
11	11-0306	Screw, socket head shoulder, 5/16" dia. x 3/8" L shoulder	1

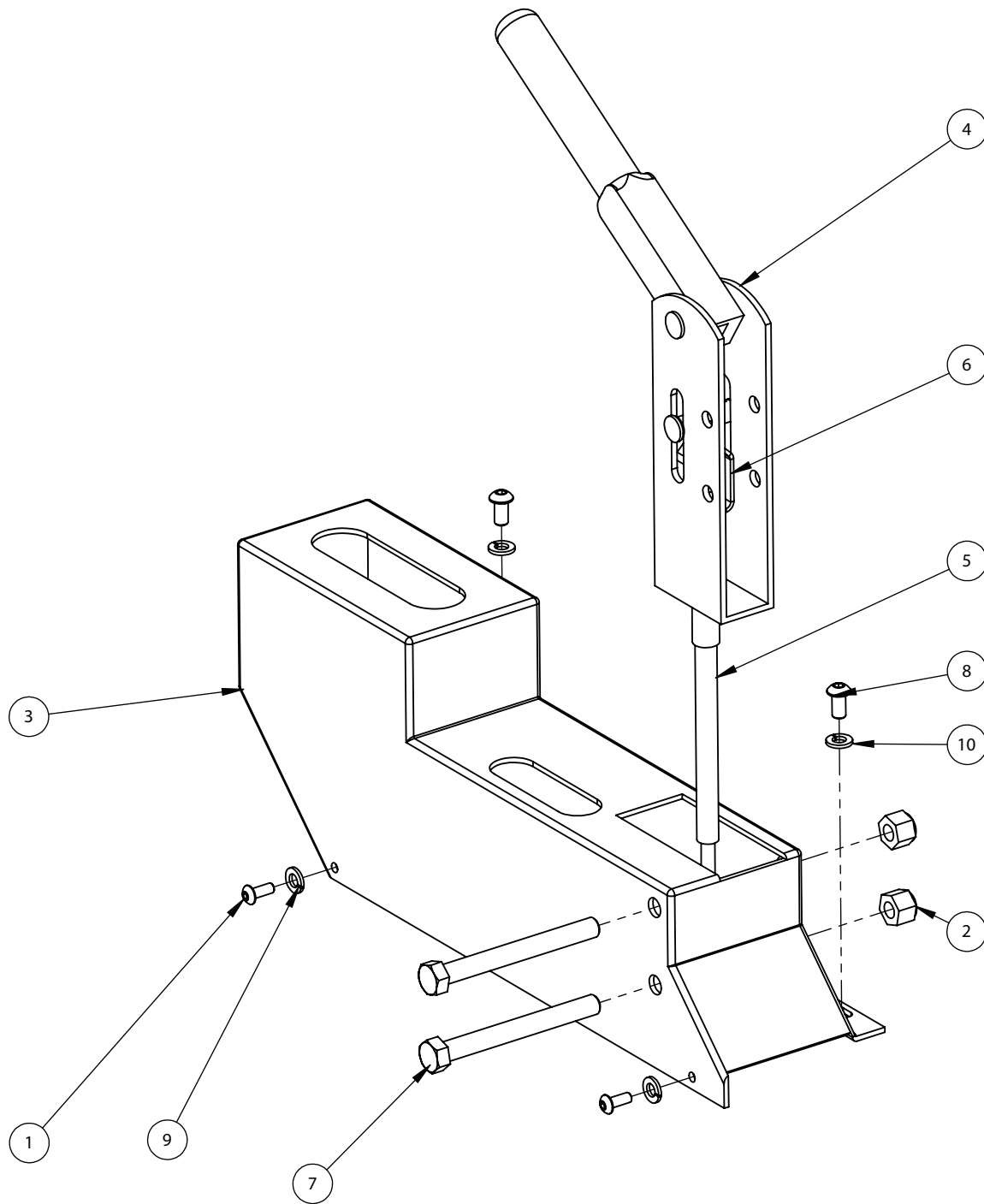

Item No.	Part Number	Description	Qty.
1	61-0056	Decal (Power limiter / oil filter / oil temp)	1
2	25-0003	Potentiometer Knob	1
3	22-0001	Potentiometer	1
4	23-0030-1	S.T.D. display	1
5	23-0031	Manual disconnect switch	1
8	52-0155	Console	1
9	25-0002	Red panel light	2



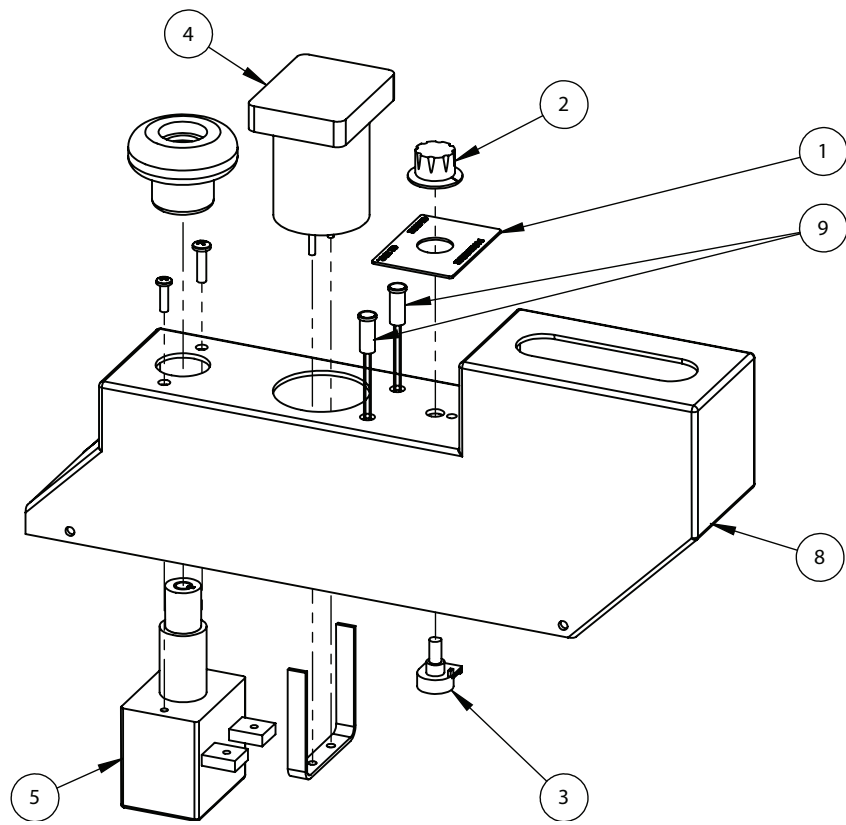

Item No.	Part Number	Description	Qty.
1	51-0702	Main linkage	1
2	51-0706	Linkage	1
3	51-0699	Yoke anchor	1
4	53-0247	Joystick rod	1
5	51-0704	Linkage	1
6	11-0003	Hex Head Cap Screw, GR5: 5/16"-18 x 1.5"L	1
7	11-0067	Steel Hex Nut, 5/16"-18, ZP	1
8	11-0024	Nut (Nylon-insert), 1/4-20	2
9	11-0040	Steel Split Lock Washer, 5/16", ZP	1
10	11-0069	Lock washer, 1/4	2
11	11-0139	Steel USS Flat Washer, 5/16" ZP	1
12	11-0164	Steel Socket Head Cap Screw, 1/4"-20 x .5"L ZP	2
13	11-0304	Socket Head Shoulder Screw, 5/16"Dia x 5/8"L Shoulder, 1/4"-20 Thread	1
14	11-0305	Screw (shoulder), 5/16 dia. x 1 long shoulder	1
15	13-0300	Knob (1-7/8 dia.)	1

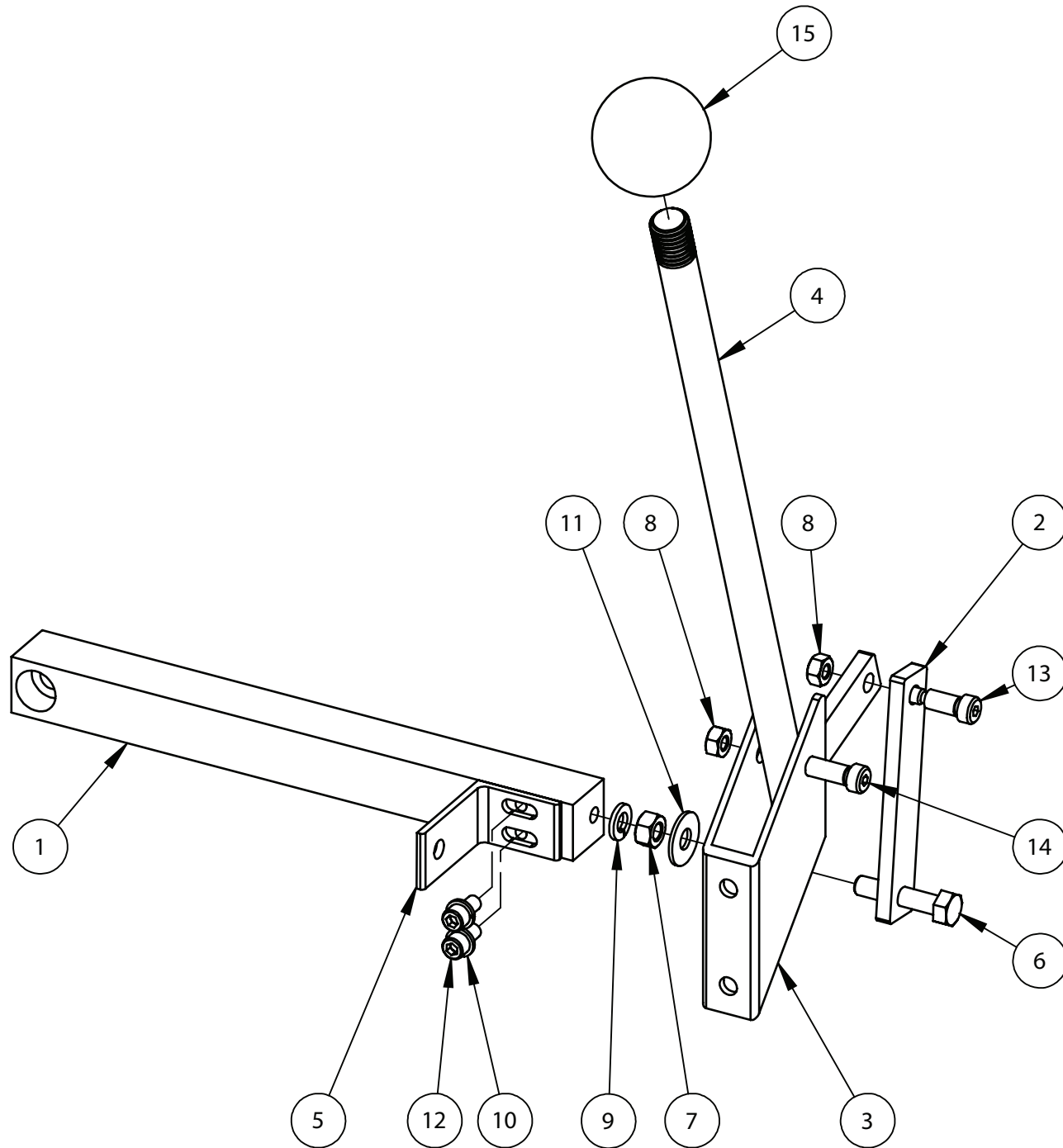

Item No.	Part Number	Description	Qty.
1	11-0067	Nut (Nylon-insert), 5/16-18	1
2	11-0024	Nut (Nylon-insert), 1/4-20	1
3	53-0236	Linkage	1
4	51-0708	Linkage	1
5	11-0118	Screw, 5/16-18 x 3/4	1
6	11-0133	Screw, 1/4-20 x 3/4	1
7	13-0299	Knob (1-1/4" dia.)	1
8	11-0129	Washer (lock), 3/8	1
9	11-0223	Nut, 3/8-16	1
10	53-0235	Linkage	1
11	53-0257	Joystick rod (with welded washer)	1

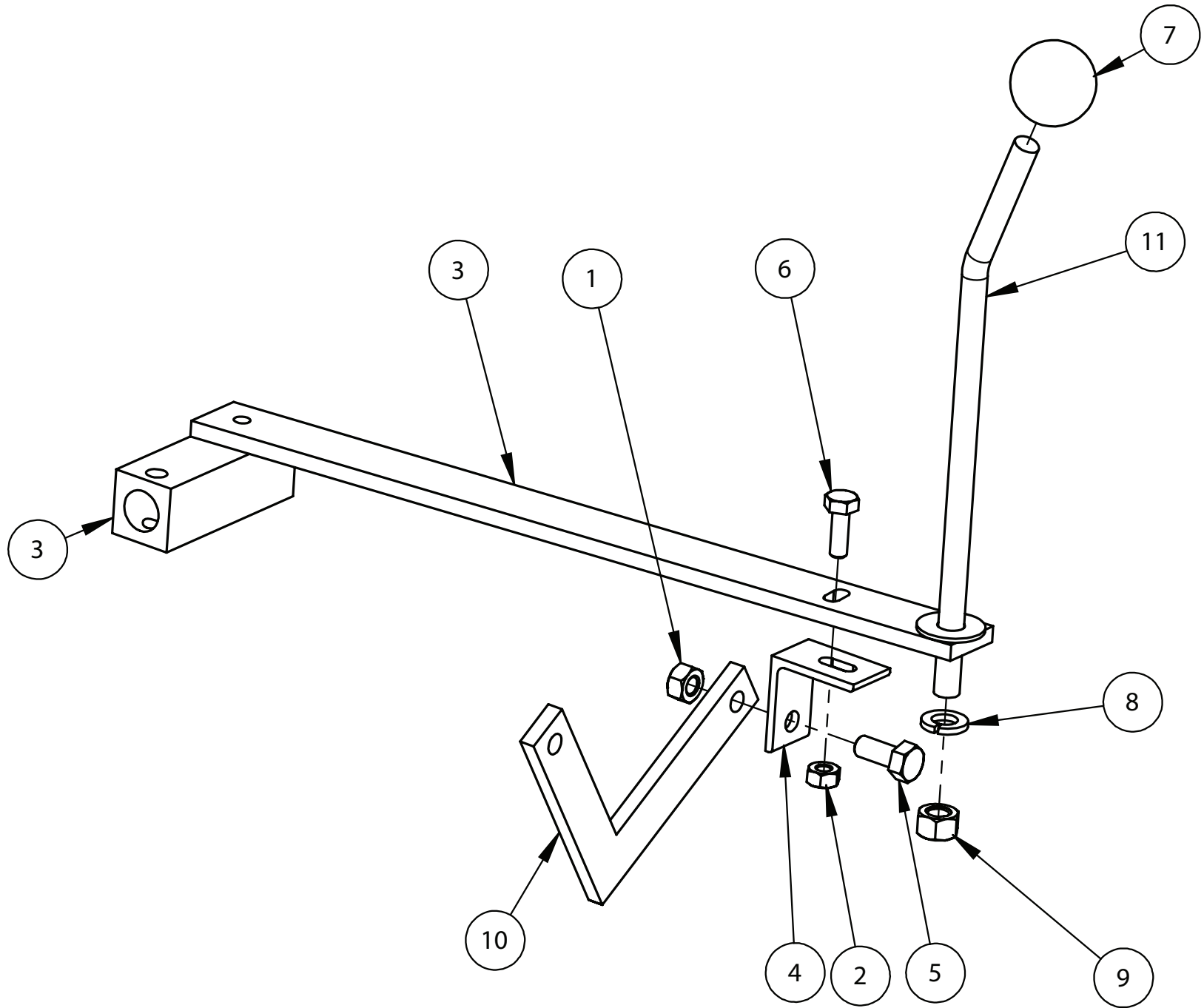

Item No.	Part Number	Description	Qty.
1	53-0151	Left door panel (painted)	1
2	13-0006	Door Latch	2
4	11-0021	Nut (Nylok), #6-32	6
5	13-0011	Hinge (for left door panel)	2
6	11-0085	Screw, pan head, Phillips, #6-32 x 1/2"	6

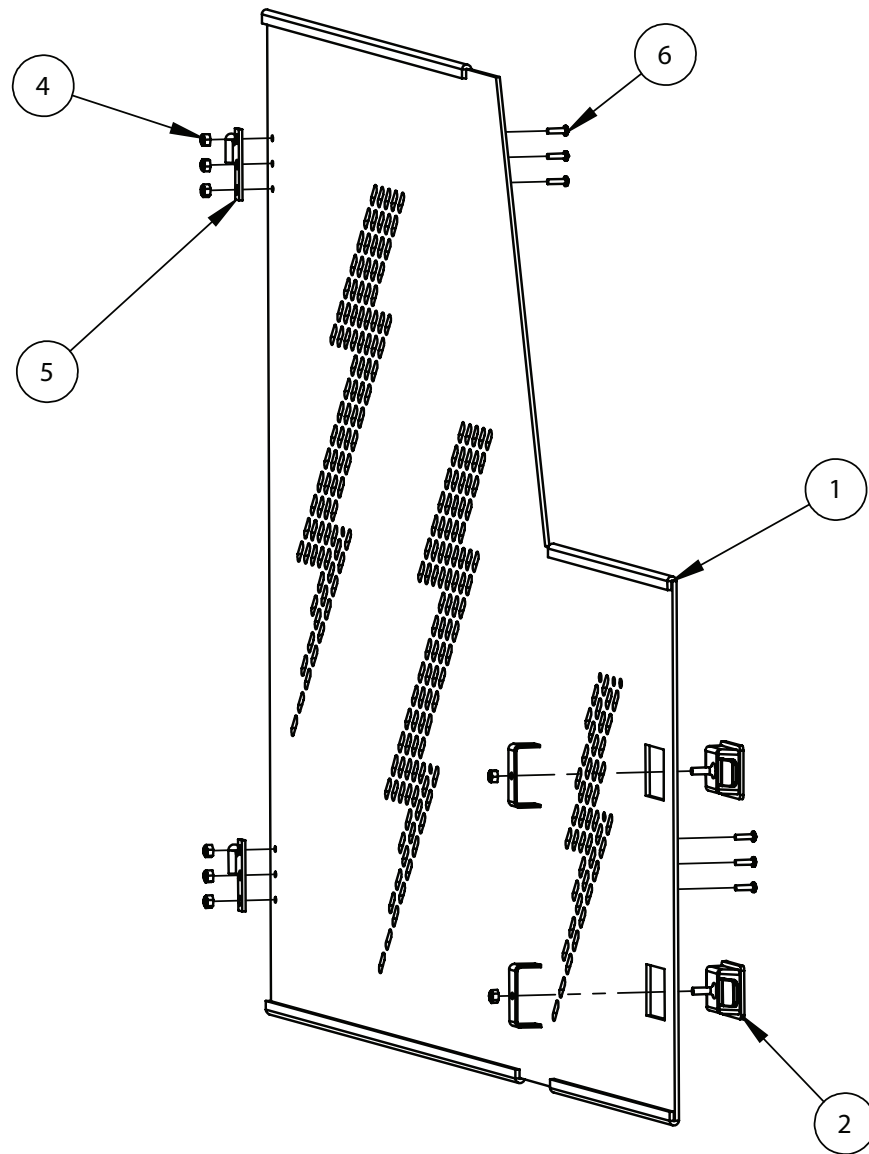

RIGHT SIDE DOOR PANEL ASSY (96-0211) IS A  
MIRRORED IMAGE OF THIS ASSY.

Item No.	Part Number	Description	Qty.
1	53-0065	Top Cover, T-2000EI, Welded & Painted	1
2	22-0005	Backup Alarm	1
3	22-0006	Strobe Light	1
4	42-0001	Fire Extinguisher	1
5	13-0005	Handle, Chrome	2
6	11-0140	Screw, Flat Head Hex Socket, 1/4"-20x .75"L, ZP	8
7	11-0024	Steel Nylon-Insert Lock Nut, 1/4"-20 ZP	10
8	11-0025	Steel Nylon-Insert Lock Nut, 5/16"-18 ZP	4
9	11-0022	Steel Nylon-Insert Lock Nut,#8-32, ZP	3
10	11-0034	Steel Flat Washer, 5/16", ZP	4
11	11-0193	Steel Hex Cap Screw 5/16"-18 x 0.75"L	4
12	11-0133	Steel Hex Head Cap Screw, Gr5, 1/4"-20 x 3/4"L, ZP	2
13	11-0102	Screw, Pan Head Phillips Machine Screw, #8-32x5/8", ZP	3
14	11-0031	Steel Flat Washer, #8	3
15	11-0033	1/4" Wide Flat Washer, Steel, ZP	4
16	11-0250-12	Screw, Pan Head Phillips Machine Screw, #10-24x3/4", ZP	2
17	11-0030	Steel SAE Flat Washer, #10	2
18	11-0023	Steel Nylon-Insert Lock Nut,#10-24, ZP	2



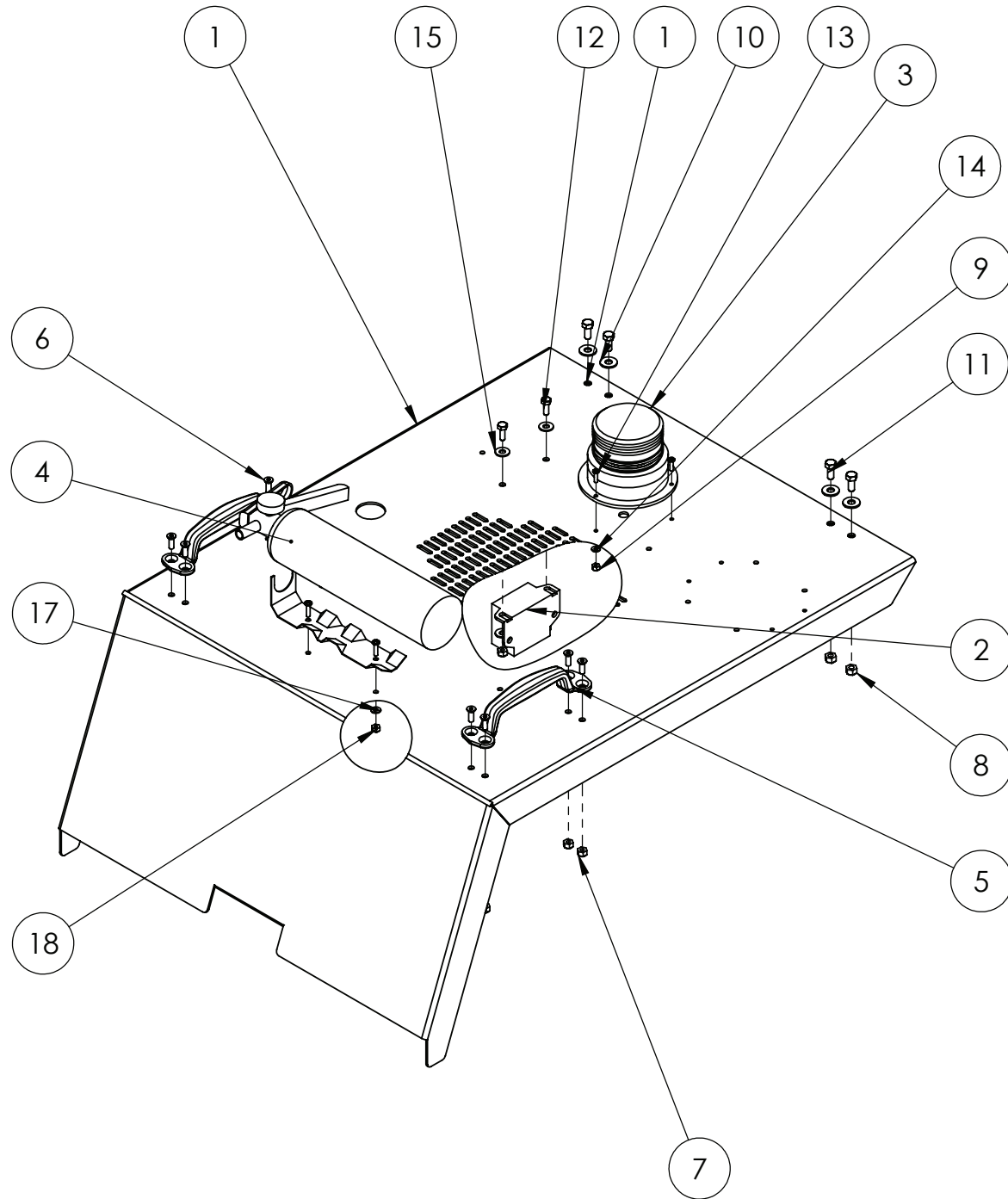

Item No.	Part Number	Description	Qty.
1	11-0069	1/4 SPLIT LOCK WASHER	4
2	11-0207	STEEL, BUTTON HEAD SOCKET CAP SCREW 1/4-20X.75	7
3	53-0155	FOOT REST	1
4	23-0097	FOOT PEDAL	1
5	53-0153	FOOT PEDAL MOUNT BRACKET	1
6	11-0024	1/4-20 NYLOCK NUT	3

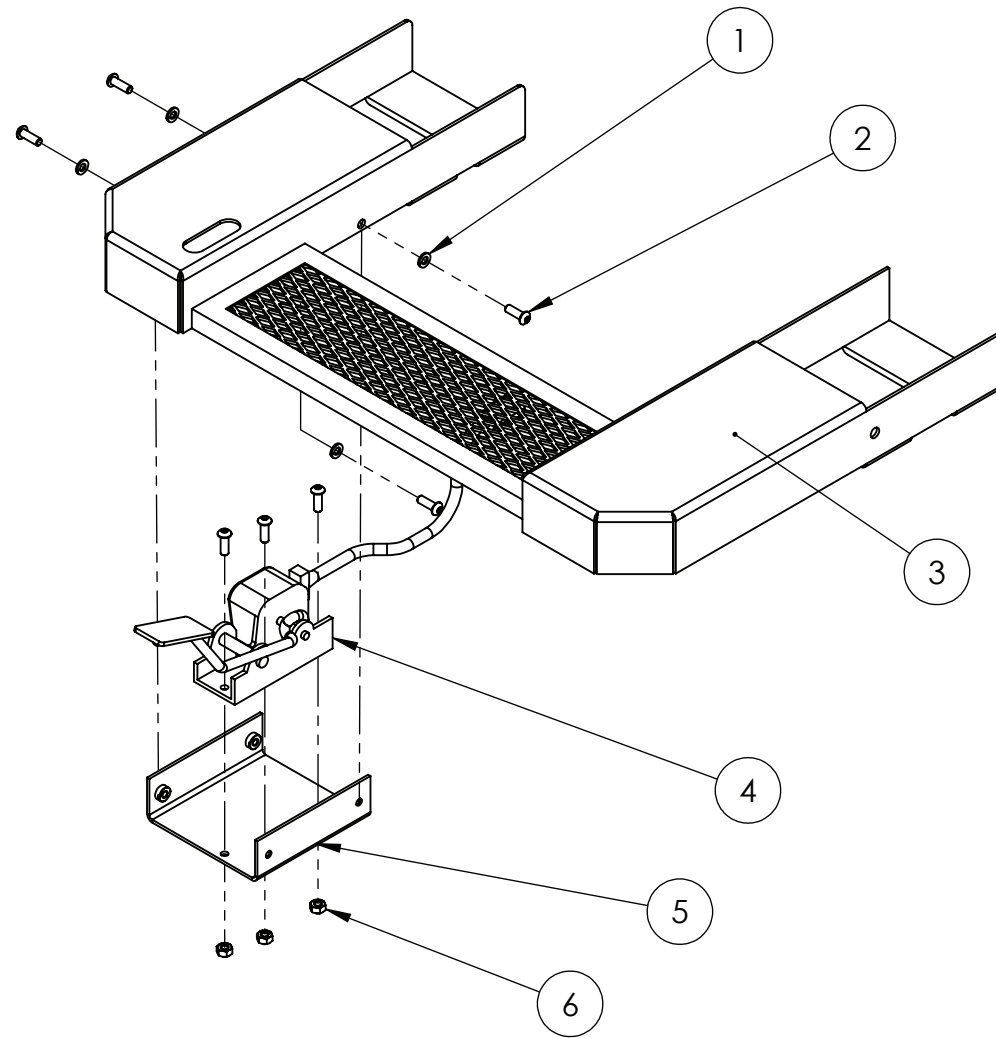

# Electrical Schematic

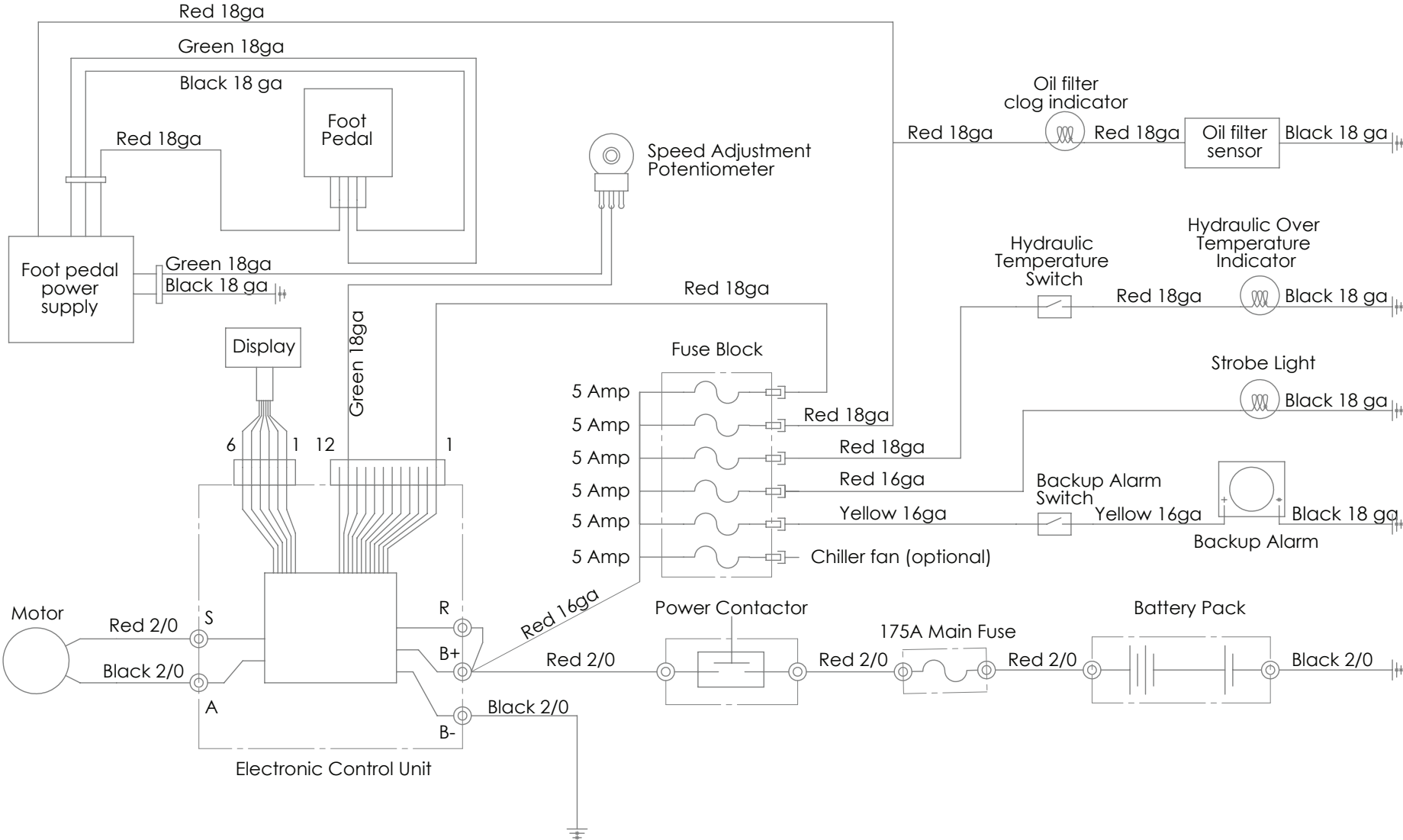





## MATERIAL SAFETY DATA SHEET

EFFECTIVE JANUARY, 2011

U.S. BATTERY MFG. CO.  
1675 SAMPSON AVE  
CORONA, CA. 92879-1889

• U.S. BATTERY MFG. CO.  
1895 TOBACCO RD.  
AUGUSTA, GA. 30906

• U.S. BATTERY MFG. CO.  
717 BELAIR RD.  
EVANS, GA. 30809

TRANSPORTATION EMERGENCY NO:

INFOTRAC: (800) 535-5053 / INT'L (352) 323-3500

GENERAL INFORMATION NO:  
SAFETY DEPT. (951) 371-8090

### SECTION I

PRODUCT NAME: BATTERY, WET, FILLED WITH ACID  
CHEMICAL NAME: LEAD / ACID STORAGE BATTERY  
CHEMICAL FAMILY: TOXIC AND CORROSIVE MATERIAL  
FORMULA: LEAD / ACID

### SECTION II

MATERIALS	CAS NUMBER	PERCENT	TLV (units)
LEAD / LEAD OXIDE	7439-92-1	43 to 70	0.05 mg/m <sup>3</sup>
ANTIMONY ALLOY	7440-36-0	.4 to 1.25	0.5 mg/m <sup>3</sup>
ARSENIC	7440-38-2	LESS THAN .01%	.01 mg/m <sup>3</sup>
SULFURIC ACID	7664-93-9	20-44	1.0 mg/m <sup>3</sup>

### SECTION III

#### PHYSICAL / CHEMICAL CHARACTERISTICS

BOILING POINT: APPROX. 203°F  
VAPOR PRESSURE (mm Hg): 10@18°F  
VAPOR DENSITY (air = 1): N/A  
SOLUBILITY IN WATER: 100%  
PERCENT VOLATILE BY VOLUME(%): 10-30%  
SPECIFIC GRAVITY: 1.145 TO 1.345  
EVAPORATION RATE: <1.0  
APPEARANCE AND ODOR: CLEAR LIQUID, PUNGENT ODOR (SHARP PENETRATING ODOR)

### SECTION IV

#### FIRE AND EXPLOSION HAZARD DATA

FLASH POINT: N/A  
FLAMMABLE LIMITS: Lel 4.0% Uel 74.2%  
EXTINGUISHING MEDIA: HALON OR DRY CHEMICAL EXTINGUISHER  
UNUSUAL FIRE AND EXPLOSION HAZARDS:  
HYDROGEN GAS AND SULFURIC ACID VAPORS ARE GENERATED UPON OVERCHARGE.  
VENTILATE CHARGING AREAS.

### SECTION V

#### HEALTH HAZARD DATA

THRESHOLD LIMIT VALUE:  
EFFECTS OF OVEREXPOSURE:  
SEE SECTION II  
EYES: SERVE BURNS, CORNEA DAMAGE AND  
BLINDNESS.  
SKIN: SERVE IRRITATION, BURNING AND  
ULCERATION.  
INHALATION: BREATHING OF VAPORS OR MIST  
MAY CAUSE RESPIRATORY DAMAGE.  
INGESTION: BURNS TO MOUTH, THROAT AND  
INTESTINAL TRACT.

SECTION V (continued)	
EMERGENCY AND FIRST AID PROCEDURES:	EYES: WASH WITH COPIOUS QUANTITIES OF RUNNING WATER SKIN: WASH WITH SOAP AND WATER INGESTION: INDUCE VOMITING
SEEK MEDICAL ATTENTION FOR ALL EXPOSURE EMERGENCIES	
SECTION VI	
<b>REACTIVITY DATA</b>	
STABILITY:	H-3,F-0,S-W,R-0 STABLE UNDER NORMAL CONDITIONS
CONDITIONS TO AVOID:	AVOID DISMANTLING AND EXPOSURE TO INTERNAL COMPONENTS.
INCOMPATIBILITY:	NONE
HAZARDOUS POLYMERIZATION:	WILL NOT OCCUR
SECTION VII	
<b>SPILL OR LEAK PROCEDURES</b>	
PRODUCT CONTAINS DRY PLATES. NO LEAKAGE IS EXPECTED UNDER NORMAL CONDITIONS AND TRANSPORTATION. IN CASE OF ACCIDENTAL SPILLAGE OF PLATES, DUST AND LEAD COMPOUNDS SHOULD BE CONTAINED. PARTICULATE MATTER SHOULD STORED IN A DRY CONTAINER AND DISPOSED IN ACCORDANCE WITH LOCAL, STATE AND FEDERAL REGULATIONS FOR LEAD PRODUCTS. DO NOT USE COMPRESSED AIR OR DRY SWEEPING AS A MEANS OF CLEANING. VACUUMING IS RECOMMENDED.	
SECTION VIII	
<b>SPECIAL PROTECTION INFORMATION</b>	
RESPIRATORY PROTECTION:	USE HEPA RESPIRATORS WHEN LEAD DUST IS PRESENT.
VENTILATION:	N/A
PROTECTIVE GLOVES:	RUBBER GLOVES SHOULD BE WORN WHEN HANDLING.
EYE PROTECTION:	SAFETY GLASSES
OTHER PROTECTIVE EQUIPMENT:	N/A
SECTION IX	
<b>SPECIAL PRECAUTIONS</b>	
NO SPECIAL HANDLING IS REQUIRED UNDER NORMAL CONDITIONS.	
TRANSPORTATION INFORMATION	
DOT SHIPPING NAME:	BATTERIES, DRY - UNFORMED
IDENTIFICATION NUMBER:	N/A
HAZARD CLASS:	N/A
SHIPPING LABELS:	NONE REQUIRED
PLACARD (when required)	NONE REQUIRED

PROPOSITION 65

**WARNING:**  
LEAD AND IT'S COMPOUNDS ARE CHEMICALS KNOWN TO THE STATE OF CALIFORNIA TO CAUSE REPRODUCTIVE HARM TO BOTH MALES AND FEMALES AND TO CAUSE BIRTH DEFECTS.

rev 01-11

d-2a

# Material Safety Data Sheet



## SECTION 1 PRODUCT AND COMPANY IDENTIFICATION

### Chevron Rando® HD

**Product Use:** Hydraulic Oil  
**Product Number(s):** CPS273277, CPS273278, CPS273279  
**Synonyms:** Rando® HD ISO 32, Rando® HD ISO 46, Rando® HD ISO 68  
**Company Identification**  
 Chevron Products Company  
 a division of Chevron U.S.A. Inc.  
 6001 Bollinger Canyon Rd.  
 San Ramon, CA 94583  
 United States of America  
 www.chevronlubricants.com

**Transportation Emergency Response**  
 CHEMTREC: (800) 424-9300 or (703) 527-3887  
**Health Emergency**  
 Chevron Emergency Information Center: Located in the USA. International collect calls accepted. (800) 231-0623 or (510) 231-0623

**Product Information**  
 email : lubemsds@chevron.com  
 Product Information: (800) LUBE TEK

## SECTION 2 COMPOSITION/ INFORMATION ON INGREDIENTS

COMPONENTS	CAS NUMBER	AMOUNT
Highly refined mineral oil (C15 - C50)	Mixture	70 - 100 %wt/wt

## SECTION 3 HAZARDS IDENTIFICATION

### IMMEDIATE HEALTH EFFECTS

**Eye:** Not expected to cause prolonged or significant eye irritation.  
**Skin:** Contact with the skin is not expected to cause prolonged or significant irritation. Contact with the skin is not expected to cause an allergic skin response. Not expected to be harmful to internal organs if absorbed through the skin. High-Pressure Equipment Information: Accidental high-velocity injection under the skin of materials of this type may result in serious injury. Seek medical attention at once should an accident like this occur. The initial wound at the injection site may not appear to be serious at first; but, if left untreated, could result in disfigurement or amputation of the affected part.

**Ingestion:** Not expected to be harmful if swallowed.

**Inhalation:** Not expected to be harmful if inhaled. Contains a petroleum-based mineral oil. May cause



respiratory irritation or other pulmonary effects following prolonged or repeated inhalation of oil mist at airborne levels above the recommended mineral oil mist exposure limit. Symptoms of respiratory irritation may include coughing and difficulty breathing.

#### SECTION 4 FIRST AID MEASURES

**Eye:** No specific first aid measures are required. As a precaution, remove contact lenses, if worn, and flush eyes with water.

**Skin:** No specific first aid measures are required. As a precaution, remove clothing and shoes if contaminated. To remove the material from skin, use soap and water. Discard contaminated clothing and shoes or thoroughly clean before reuse.

**Ingestion:** No specific first aid measures are required. Do not induce vomiting. As a precaution, get medical advice.

**Inhalation:** No specific first aid measures are required. If exposed to excessive levels of material in the air, move the exposed person to fresh air. Get medical attention if coughing or respiratory discomfort occurs.

**Note to Physicians:** In an accident involving high-pressure equipment, this product may be injected under the skin. Such an accident may result in a small, sometimes bloodless, puncture wound. However, because of its driving force, material injected into a fingertip can be deposited into the palm of the hand. Within 24 hours, there is usually a great deal of swelling, discoloration, and intense throbbing pain. Immediate treatment at a surgical emergency center is recommended.

#### SECTION 5 FIRE FIGHTING MEASURES

Leaks/ruptures in high pressure system using materials of this type can create a fire hazard when in the vicinity of ignition sources (eg. open flame, pilot lights, sparks, or electric arcs).

##### FIRE CLASSIFICATION:

OSHA Classification (29 CFR 1910.1200): Not classified by OSHA as flammable or combustible.

**NFPA RATINGS:** Health: 0 Flammability: 1 Reactivity: 0

##### FLAMMABLE PROPERTIES:

**Flashpoint:** (Cleveland Open Cup) 170 °C (338 °F) Minimum

**Autoignition:** No data available

**Flammability (Explosive) Limits (% by volume in air):** Lower: Not Applicable Upper: Not Applicable

**EXTINGUISHING MEDIA:** Use water fog, foam, dry chemical or carbon dioxide (CO<sub>2</sub>) to extinguish flames.

##### PROTECTION OF FIRE FIGHTERS:

**Fire Fighting Instructions:** This material will burn although it is not easily ignited. For fires involving this material, do not enter any enclosed or confined fire space without proper protective equipment, including self-contained breathing apparatus.

**Combustion Products:** Highly dependent on combustion conditions. A complex mixture of airborne solids, liquids, and gases including carbon monoxide, carbon dioxide, and unidentified organic compounds will be evolved when this material undergoes combustion.

#### SECTION 6 ACCIDENTAL RELEASE MEASURES

Revision Number: 2

Revision Date: FEBRUARY 16, 2012

2 of 7

Chevron Rando® HD  
MSDS : 23556

**Protective Measures:** Eliminate all sources of ignition in vicinity of spilled material.  
**Spill Management:** Stop the source of the release if you can do it without risk. Contain release to prevent further contamination of soil, surface water or groundwater. Clean up spill as soon as possible, observing precautions in Exposure Controls/Personal Protection. Use appropriate techniques such as applying non-combustible absorbent materials or pumping. Where feasible and appropriate, remove contaminated soil. Place contaminated materials in disposable containers and dispose of in a manner consistent with applicable regulations.

**Reporting:** Report spills to local authorities and/or the U.S. Coast Guard's National Response Center at (800) 424-8802 as appropriate or required.

## SECTION 7 HANDLING AND STORAGE

**Precautionary Measures:** DO NOT USE IN HIGH PRESSURE SYSTEMS in the vicinity of flames, sparks and hot surfaces. Use only in well ventilated areas. Keep container closed.

**General Handling Information:** Avoid contaminating soil or releasing this material into sewage and drainage systems and bodies of water.

**Static Hazard:** Electrostatic charge may accumulate and create a hazardous condition when handling this material. To minimize this hazard, bonding and grounding may be necessary but may not, by themselves, be sufficient. Review all operations which have the potential of generating and accumulating an electrostatic charge and/or a flammable atmosphere (including tank and container filling, splash filling, tank cleaning, sampling, gauging, switch loading, filtering, mixing, agitation, and vacuum truck operations) and use appropriate mitigating procedures. For more information, refer to OSHA Standard 29 CFR 1910.106, 'Flammable and Combustible Liquids', National Fire Protection Association (NFPA 77, 'Recommended Practice on Static Electricity', and/or the American Petroleum Institute (API) Recommended Practice 2003, 'Protection Against Ignitions Arising Out of Static, Lightning, and Stray Currents'.

**Container Warnings:** Container is not designed to contain pressure. Do not use pressure to empty container or it may rupture with explosive force. Empty containers retain product residue (solid, liquid, and/or vapor) and can be dangerous. Do not pressurize, cut, weld, braze, solder, drill, grind, or expose such containers to heat, flame, sparks, static electricity, or other sources of ignition. They may explode and cause injury or death. Empty containers should be completely drained, properly closed, and promptly returned to a drum reconditioner or disposed of properly.

## SECTION 8 EXPOSURE CONTROLS/PERSONAL PROTECTION

### GENERAL CONSIDERATIONS:

Consider the potential hazards of this material (see Section 3), applicable exposure limits, job activities, and other substances in the work place when designing engineering controls and selecting personal protective equipment. If engineering controls or work practices are not adequate to prevent exposure to harmful levels of this material, the personal protective equipment listed below is recommended. The user should read and understand all instructions and limitations supplied with the equipment since protection is usually provided for a limited time or under certain circumstances.

### ENGINEERING CONTROLS:

Use in a well-ventilated area.

### PERSONAL PROTECTIVE EQUIPMENT

**Eye/Face Protection:** No special eye protection is normally required. Where splashing is possible, wear safety glasses with side shields as a good safety practice.

**Skin Protection:** No special protective clothing is normally required. Where splashing is possible, select protective clothing depending on operations conducted, physical requirements and other substances in the workplace. Suggested materials for protective gloves include: 4H (PE/EVAL), Nitrile Rubber, Silver

Revision Number: 2

Revision Date: FEBRUARY 16, 2012

3 of 7

Chevron Rando® HD  
MSDS : 23556

Shield, Viton.

**Respiratory Protection:** No respiratory protection is normally required. If user operations generate an oil mist, determine if airborne concentrations are below the occupational exposure limit for mineral oil mist. If not, wear an approved respirator that provides adequate protection from the measured concentrations of this material. For air-purifying respirators use a particulate cartridge. Use a positive pressure air-supplying respirator in circumstances where air-purifying respirators may not provide adequate protection.

#### Occupational Exposure Limits:

Component	Agency	TWA	STEL	Ceiling	Notation
Highly refined mineral oil (C15 - C50)	ACGIH	5 mg/m <sup>3</sup>	10 mg/m <sup>3</sup>	--	--
Highly refined mineral oil (C15 - C50)	OSHA Z-1	5 mg/m <sup>3</sup>	--	--	--

Consult local authorities for appropriate values.

### SECTION 9 PHYSICAL AND CHEMICAL PROPERTIES

Attention: the data below are typical values and do not constitute a specification.

**Color:** Yellow

**Physical State:** Liquid

**Odor:** Petroleum odor

**pH:** Not Applicable

**Vapor Pressure:** <0.01 mmHg @ 37.8 °C (100 °F)

**Vapor Density (Air = 1):** >1

**Boiling Point:** >315°C (599°F)

**Solubility:** Soluble in hydrocarbon solvents; insoluble in water.

**Freezing Point:** Not Applicable

**Density:** 0.87 kg/l @ 15°C (59°F) (Typical)

**Viscosity:** 28.8 mm<sup>2</sup>/s @ 40°C (104°F) Minimum

### SECTION 10 STABILITY AND REACTIVITY

**Chemical Stability:** This material is considered stable under normal ambient and anticipated storage and handling conditions of temperature and pressure.

**Incompatibility With Other Materials:** May react with strong acids or strong oxidizing agents, such as chlorates, nitrates, peroxides, etc.

**Hazardous Decomposition Products:** None known (None expected)

**Hazardous Polymerization:** Hazardous polymerization will not occur.

### SECTION 11 TOXICOLOGICAL INFORMATION

#### IMMEDIATE HEALTH EFFECTS

**Eye Irritation:** The eye irritation hazard is based on evaluation of data for similar materials or product components.

**Skin Irritation:** The skin irritation hazard is based on evaluation of data for similar materials or product components.

**Skin Sensitization:** The skin sensitization hazard is based on evaluation of data for similar materials or product components.

**Acute Dermal Toxicity:** The acute dermal toxicity hazard is based on evaluation of data for similar materials or product components.

Revision Number: 2

Revision Date: FEBRUARY 16, 2012

4 of 7

Chevron Rando® HD  
MSDS : 23556

**Acute Oral Toxicity:** The acute oral toxicity hazard is based on evaluation of data for similar materials or product components.

**Acute Inhalation Toxicity:** The acute inhalation toxicity hazard is based on evaluation of data for similar materials or product components.

**ADDITIONAL TOXICOLOGY INFORMATION:**

This product contains petroleum base oils which may be refined by various processes including severe solvent extraction, severe hydrocracking, or severe hydrotreating. None of the oils requires a cancer warning under the OSHA Hazard Communication Standard (29 CFR 1910.1200). These oils have not been listed in the National Toxicology Program (NTP) Annual Report nor have they been classified by the International Agency for Research on Cancer (IARC) as; carcinogenic to humans (Group 1), probably carcinogenic to humans (Group 2A), or possibly carcinogenic to humans (Group 2B). These oils have not been classified by the American Conference of Governmental Industrial Hygienists (ACGIH) as: confirmed human carcinogen (A1), suspected human carcinogen (A2), or confirmed animal carcinogen with unknown relevance to humans (A3).

**SECTION 12 ECOLOGICAL INFORMATION**

**ECOTOXICITY**

This material is not expected to be harmful to aquatic organisms. The ecotoxicity hazard is based on an evaluation of data for the components or a similar material.

**ENVIRONMENTAL FATE**

**Ready Biodegradability:** This material is not expected to be readily biodegradable. The biodegradability of this material is based on an evaluation of data for the components or a similar material.

**SECTION 13 DISPOSAL CONSIDERATIONS**

Use material for its intended purpose or recycle if possible. Oil collection services are available for used oil recycling or disposal. Place contaminated materials in containers and dispose of in a manner consistent with applicable regulations. Contact your sales representative or local environmental or health authorities for approved disposal or recycling methods.

**SECTION 14 TRANSPORT INFORMATION**

The description shown may not apply to all shipping situations. Consult 49CFR, or appropriate Dangerous Goods Regulations, for additional description requirements (e.g., technical name) and mode-specific or quantity-specific shipping requirements.

**DOT Shipping Description:** PETROLEUM LUBRICATING OIL, NOT REGULATED AS A HAZARDOUS MATERIAL FOR TRANSPORTATION UNDER 49 CFR

**IMO/IMDG Shipping Description:** PETROLEUM LUBRICATING OIL; NOT REGULATED AS DANGEROUS GOODS FOR TRANSPORT UNDER THE IMDG CODE

**ICAO/IATA Shipping Description:** PETROLEUM LUBRICATING OIL; NOT REGULATED AS DANGEROUS GOODS FOR TRANSPORT UNDER ICAO TI OR IATA DGR

**SECTION 15 REGULATORY INFORMATION**

Revision Number: 2  
Revision Date: FEBRUARY 16, 2012

5 of 7

Chevron Rando® HD  
MSDS : 23556

**EPCRA 311/312 CATEGORIES:**

- |                                       |    |
|---------------------------------------|----|
| 1. Immediate (Acute) Health Effects:  | NO |
| 2. Delayed (Chronic) Health Effects:  | NO |
| 3. Fire Hazard:                       | NO |
| 4. Sudden Release of Pressure Hazard: | NO |
| 5. Reactivity Hazard:                 | NO |

**REGULATORY LISTS SEARCHED:**

- 01-1=IARC Group 1
- 01-2A=IARC Group 2A
- 01-2B=IARC Group 2B
- 02=NTP Carcinogen
- 03=EPCRA 313
- 04=CA Proposition 65
- 05=MA RTK
- 06=NJ RTK
- 07=PA RTK

No components of this material were found on the regulatory lists above.

**CHEMICAL INVENTORIES:**

All components comply with the following chemical inventory requirements: AICS (Australia), DSL (Canada), EINECS (European Union), ENCS (Japan), IECSC (China), KECI (Korea), PICCS (Philippines), TSCA (United States).

**NEW JERSEY RTK CLASSIFICATION:**

Under the New Jersey Right-to-Know Act L. 1983 Chapter 315 N.J.S.A. 34:5A-1 et. seq., the product is to be identified as follows: PETROLEUM OIL (Hydraulic oil)

**WHMIS CLASSIFICATION:**

This product is not considered a controlled product according to the criteria of the Canadian Controlled Products Regulations.

**SECTION 16 OTHER INFORMATION**

**NFPA RATINGS:** Health: 0 Flammability: 1 Reactivity: 0

**HMIS RATINGS:** Health: 1 Flammability: 1 Reactivity: 0  
 (0-Least, 1-Slight, 2-Moderate, 3-High, 4-Extreme, PPE:- Personal Protection Equipment Index recommendation, \*- Chronic Effect Indicator). These values are obtained using the guidelines or published evaluations prepared by the National Fire Protection Association (NFPA) or the National Paint and Coating Association (for HMIS ratings).

**LABEL RECOMMENDATION:**

Label Category : INDUSTRIAL OIL 1 - IND1

**REVISION STATEMENT:** This revision updates the following sections of this Material Safety Data Sheet: 1,2,9,16

**Revision Date:** FEBRUARY 16, 2012

**ABBREVIATIONS THAT MAY HAVE BEEN USED IN THIS DOCUMENT:**

TLV - Threshold Limit Value	TWA - Time Weighted Average
STEL - Short-term Exposure Limit	PEL - Permissible Exposure Limit
	CAS - Chemical Abstract Service Number

Revision Number: 2  
 Revision Date: FEBRUARY 16, 2012

6 of 7

Chevron Rando® HD  
 MSDS : 23556

ACGIH - American Conference of Governmental Industrial Hygienists	IMO/IMDG Code	International Maritime Dangerous Goods
API - American Petroleum Institute	MSDS	Material Safety Data Sheet
CVX - Chevron	NFPA	National Fire Protection Association (USA)
DOT - Department of Transportation (USA)	NTP	National Toxicology Program (USA)
IARC - International Agency for Research on Cancer	OSHA Administration	Occupational Safety and Health

Prepared according to the OSHA Hazard Communication Standard (29 CFR 1910.1200) and the ANSI MSDS Standard (Z400.1) by the Chevron Energy Technology Company, 100 Chevron Way, Richmond, California 94802.

**The above information is based on the data of which we are aware and is believed to be correct as of the date hereof. Since this information may be applied under conditions beyond our control and with which we may be unfamiliar and since data made available subsequent to the date hereof may suggest modifications of the information, we do not assume any responsibility for the results of its use. This information is furnished upon condition that the person receiving it shall make his own determination of the suitability of the material for his particular purpose.**

Revision Number: 2  
Revision Date: FEBRUARY 16, 2012

7 of 7

Chevron Rando® HD  
MSDS : 23556

To find more information about our other tools and products visit our website at:

[www.InnovatechProducts.com](http://www.InnovatechProducts.com)

Contact us by E-Mail at:

[Sales@InnovatechProducts.com](mailto:Sales@InnovatechProducts.com)

Contact us by Phone at:

1.800.267.6682

Contact us by U.S. Mail at:

832 80th ST SW  
Everett, WA 98203, U.S.A.

