

# **BARTELL**

**CONCRETE EQUIPMENT**

**OWNER'S MANUAL & PARTS BOOK**

## **SURFACE PREPARATION SYSTEMS (SPS)**



**POWERFULL - EFFICIENT - DEPENDABLE**

**BARTELL MORRISON INC.      BARTELL MORRISON (USA) LLC**  
**375 ANNAGEM BLVD, MISSISSAUGA, ONTARIO, CANADA, L5T 3A7, 905-364-4200 FAX 905-364-4201**  
**25 INDUSTRIAL DRIVE, KEYPORT, NEW JERSEY, USA, 07735, 732-566-5400 FAX 732-5444**

Doc. # OIPB-B09011  
Orig. Rel. - 05/2007  
Curr. Rev. - 12  
Rev. Date - 07/2015

# SURFACE PREPARATION SYSTEM OWNER'S MANUAL & PARTS BOOK

<b>SAFETY PRECAUTIONS</b>	
	<p style="text-align: center;"> <b>DANGER</b></p> <p><b>EXPLOSION HAZARD</b>                      Never operate the machine in an explosive atmosphere, near combustible materials or where ventilation does not clear exhaust fumes.</p>
	<p style="text-align: center;"> <b>WARNING</b></p> <p><b>BURN HAZARD</b>                      Never come into contact with the engine or muffler when engine is operating or shortly after it is turned off. Serious burns may occur.</p>
	<p style="text-align: center;"> <b>CAUTION</b></p> <p><b>MOVING PARTS</b>                      Before starting the machine ensure that all guards and safety devices are in place and functioning properly.</p>
	<p style="text-align: center;"> <b>CAUTION</b></p> <p><b>MACHINE DAMAGE</b>                      Advance cutter depth in small increments to avoid premature blade wear or damage.</p>
	<p style="text-align: center;"> <b>ATTENTION</b></p> <p><b>READ OWNERS MANUAL</b>                      Read and understand operator's manual before using this machine. Failure to follow operating instructions could result in serious injury or death.</p>

# SURFACE PREPARATION SYSTEM OWNER'S MANUAL & PARTS BOOK

## TABLE OF CONTENTS

QUALITY ASSURANCE/MACHINE BREAK-IN .....	4
SURFACE PREPARATION SYSTEM WARRANTY .....	5
MAINTENANCE RECORD .....	6
ROUTINE SERVICE INTERVALS .....	7
FOREWORD .....	9
SAFETY PRECAUTIONS .....	9
OPERATING PRINCIPLE .....	9
WORKING WITH THE SPS .....	9
CUTTER LIFE .....	9
GENERAL APPLICATION .....	9
TYPICAL APPLICATIONS .....	10
SAFETY PRECAUTIONS .....	10
ASSEMBLY INSTRUCTIONS .....	10
1. HANDLE INSTALLATION .....	10
2. EDGER INSTALLATION .....	11
3. STOP-SWITCH INSTALLATION .....	11
STARTING AND STOPPING PROCEDURE .....	12
MAINTENANCE .....	12
BEARING REPLACEMENT PROCEDURES .....	13
A. SEALED BEARING REPLACEMENT - OUTBOARD SIDE .....	13
B. BEARING REPLACEMENT - DRIVER OR "V" BELT SIDE .....	13
CUTTER CAGE REMOVAL & CUTTER CHANGE .....	13
EDGER CAGE REMOVAL .....	13
STORAGE .....	14
LUBRICATION, ENGINE OIL .....	14
ASSEMBLY DRAWINGS AND PARTS LIST .....	15
1. SP8 GAS ASSEMBLY (FIGURE 1) .....	16
SP8 GAS PARTS LIST .....	17
2. SP8 ELECTRIC ASSEMBLY (FIGURE 2) .....	18
SP8 ELECTRIC PARTS LIST .....	19
3. SP8 AIR ASSEMBLY (FIGURE 3) .....	21
SP8 AIR PARTS LIST .....	22
4. HANDLE ASSEMBLY (FIGURE 4) .....	24
HANDLE ASSEMBLY PARTS LIST .....	25
5. REAR WHEEL ASSEMBLY (FIGURE 5) .....	26
REAR WHEEL ASSEMBLY PARTS LIST .....	27
TROUBLESHOOTING .....	28
APPLICATIONS, CUTTERS AND CAGES INFORMATION .....	29
SPECIFICATIONS .....	30
EC DECLARATION .....	31
NOTES .....	33

## **QUALITY ASSURANCE / MACHINE BREAK IN**

The Bartell Surface Preparation System is the product of extensive engineering development designed to give long life and unmatched performance. The SPS's are shipped completely assembled with the exception of attaching the handle, and only require filling with fuel and a brief check of lubricant levels in preparation for operation.

You can help ensure that your Surface Preparation machine will perform at top levels by observing a simple routing on first use. Consider that your new SPS is like a new car. Just as you would break in a new car to the road or any new machine to the job, you should start gradually and build up to full use. Learn what your machine can do and how it will respond. Refer to the engine manufacturer's manual for run-in times. Full throttle and control may be used after this time period, as allowed by material. This will serve to further break in the machine on your specific application, as well as provide you with additional practice using the machine.

We thank you for the confidence you have placed in us by purchasing a Bartell Surface Preparation System and wish you many years of satisfied use.

# SURFACE PREPARATION SYSTEM OWNER'S MANUAL & PARTS BOOK

## SURFACE PREPARATION SYSTEM WARRANTY

**Bartell agrees to furnish without charge, F.O.B. our plant, a replacement for any part or portion thereof, Bartell SPS Machine, save and except, all cutting tools and holders, drive belts, power units, and/or electrical controls which prove upon our examination, to be defective in either material or workmanship within a period of 90 days from date of purchase, provided that notice of such defective part or portion thereof is given to Bartell Ltd. within the said period of 90 days. No further or other guarantee or warranty expressed or implied in connection with the sale of the SPS Machine is given and our sole liability consists in replacing defective parts or portions aforesaid. We shall not be responsible for any special, indirect or consequential damages arising in any manner whatsoever.**

**This guarantee is for the sole benefit of the original purchaser. Our responsibility under this guarantee ends in the case the original purchaser transfers ownership of the SPS Machine, makes any changes or adds any parts or devices not of our manufacture to the SPS Machine.**





# SURFACE PREPARATION SYSTEM OWNER'S MANUAL & PARTS BOOK

<b>Routine Service Intervals</b>		Each use	After 1.5 months or 50 hrs	Each 3 months or 100 hrs	Each 6 months or 200 hrs	Each 9 months or 300 hrs	Each 12 months or 400 hrs
<b>General Inspection:</b>							
Guards	Check		o	o	o	o	o
Warning stickers	Check		o	o	o	o	o
Wheels	Check operation	o	o	o	o	o	o
Test run	Check operation		o	o	o	o	o
<b>Engine:</b>							
Engine oil	Check level	o	o	o	o	o	o
	Change		o		o		o
Engine oil filter	Replace				o		o
Oil cooler	Clean			o	o	o	o
Cooling Fins	Clean		o	o	o	o	o
Air cleaner	Check - clean	o	o	o	o	o	o
	Replace						o
Air Intake Line	Check				o		
	Replace						2 yrs
Fan Belt	Check tightness				o		o
	Replace						500 hrs
Valve clearance	Check-adjust				o		o
Fuel filter	Check & clean			o	o	o	o
	Replace				o		o
Fuel Tank	Clean						500 hrs
Engine wiring	Check						o
<b>Cage:</b>							
Teeth: (see Individual Cage for specifications)	Check wear	o	o	o	o	o	o
	Change						
Shaft: (see Individual Cage for specifications)	Check wear	o	o	o	o	o	o
	Change						

## Routine Service Intervals

The machine is generally run in very dusty conditions. Engine life will be extended by maintaining a clean engine and using a proper dust control system. Keep the air filter clean at all times. Wash the element in a non-oil based solvent. Squeeze out any residue and allow the filter to dry before reinstalling the air cleaner. Some general maintenance guidelines will extend the useful life of your trowel.

- The initial service for your SPS Machine should be performed after 25 hours of use, at which time your mechanic (or authorized repair shop) should complete all of the recommended checks in the schedule above. The chart on page 6 (six) is handy for keeping a record of the maintenance performed and the parts used for servicing your trowel.
- Regular service according to the schedule above will prolong the life of the surface preparation system and prevent expensive repairs.
- Keeping your SPS Machine clean and free from debris is the single most important regular maintenance operation, over and above the checks in the service schedule above, that can be performed. After each use your SPS Machine should be cleaned to remove any dust and debris from the undercarriage and surrounding components. Use of a power washer will make clean up quick and easy, especially if a non-stick coating was applied prior to use.
- In the Service Schedule above, items that should be checked, replaced or adjusted are indicated by "o" in the appropriate column. Not all SPS models include the same features and options and as such not all service operations may have to be performed. For ease of recording place a checkmark (✓) through the "o" when the item is complete. If an item is not required or not completed place an "x" through the "o" in the box.
- All SPS Machines have governed engine speed of 3600 rpm. See engine manufacturer's manual for exact specifications. Care should be used when making any adjustments to the SPS Machine not to change the governed speed. Running the engine at lower rpm's will cause the cutters to skip over the surface rather than cut into it. It will create excessive "out-of-synch" vibrations resulting in poor surface results, handling, maneuverability, and discomfort to the operator.
- Failure to have your Surface Preparation System regularly serviced and properly maintained in accordance with the manufacturer's instructions will lead to premature failure and void the warranty.



# SURFACE PREPARATION SYSTEM OWNER'S MANUAL & PARTS BOOK

## FOREWORD

It is important that the following information be read carefully in order that the operational characteristics and performance of the Bartell Surface Preparation System be fully understood. Proper adherence to operation and maintenance procedures will ensure long life and top performance of your equipment.

## SAFETY PRECAUTIONS

- Always keep unauthorized, inexperienced, untrained people away from this machine.
- Rotating and moving parts will cause injury if contacted. Make sure guards are in place. Keep hands and feet away from moving parts.
- Fuel the machine only when the engine is stopped, using all necessary safety precautions.
- The engine must always be stopped before attempting any repair or adjustments. Ignition switch should be off. **Danger: Never operate the machine in an explosive atmosphere, near combustible materials or where ventilation does not clear exhaust fumes. Repair fuel leaks immediately. Refer to your engine owner's manual for more safety instructions.**
- Be careful not to come in contact with the muffler when the engine is hot, serious burns may result!
- Do not run the air motor without sufficient oil in the lubrication system. The lubricant levels should be checked regularly on gas and air powered units. Refer to manufacturer's manual for amounts.
- Before starting you SPS machine, always raise the cutter cage assembly using the hand knob adjustment, so that cutters do not contact the surface.

## OPERATING PRINCIPLE

The SPS employs a belt-pulley drive, for the cages which contact the surfaces to be prepared. The hand knob adjustment allows the cages to be raised or lowered as necessary to perform efficient work. The vibration isolators on the bridge make it easier on the operator and the machine, while the hexagonal drive bearing produces more positive cutter engagement. A dust control vacuum should be used to provide a clean work area.

The SPS Machine is designed to run at an engine speed (engine take off shaft) of 3600 rpm. (normally considered full throttle).

Never force the cutter head into the surface to a point where the machine starts to bounce. This will minimize results and do more damage to the machine than the work surface. Let the cutters do the work, but make sure you have the best cutter/cage assembly for the job.

## WORKING WITH THE SPS

We have found that working the machine in a figure "8" pattern, when milling misaligned concrete slabs or joints will produce more aggressive removal of material. The cutters will work against the cut and tend to produce more consistent and faster removal of material. Moving the machine in a straight line tends to create grooves that the cutters will follow. The Tungsten Carbide Tipped cutters produce the longest life in milling applications and should be considered as the best choice, in spite of the higher initial costs. Your time is valuable and when you have to change cutters or even cutter assemblies you are not using the machine to make money.

When using the SPS to mill concrete, work the left side or belt guard side, riding on the high side of the cut, if possible. This will avoid the possibility of the drive pulley engaging the work surface. Regularly check that the drive pulley is aligned properly and secured to the drive shaft.

When using any Cutter Cage Assemblies, there will be variations in the floor. The depth of cut should be adjusted with the hand knob to maintain an equal penetration of the work surface.

Grooving set ups are possible with the SPS in as many configurations as you need. The normal set up of the R123 uses cutters spaced with 1" centers, braced by tension springs. They could also be set up with other centers, but bear in mind that they must always be tensioned to maintain the path you require. Checkerboard effects are possible by working the machine at 90° to the path first established.

When using the Edger attachment for crack chasing, try the following method. Mark the front of the edger with a chalk guide line to correspond to the starting point of the crack. Lower the head into the crack and push the machine forward along the fault line using the chalk mark as the steering guide. Using carbides gives the longest life, but B-2 and B-3 cutters may also be used in the set up. Always tension the cutters in the cage with spring load to maintain a consistent path.

## CUTTER LIFE

How long cutters and cages last on a particular job is a difficult thing to predict. There are a number of variables involved which must always be considered. How old/hard is the material you are working with? Are there any hardeners or additives that will slow you down? Are you forcing the cage into the surface? Is the equipment properly maintained? Is the operator familiar with the machine and its capabilities? Do you have the proper cutter/cage set up for the application?

There are additional cutters and cages to those below, but this is a fair representation of estimated rates for production and cutter life. We preset them as a guide only, due to variables such as above.

# SURFACE PREPARATION SYSTEM OWNER'S MANUAL & PARTS BOOK

## GENERAL APPLICATION

### ADHESIVES – CARPET

#### R120 (B-1 Cutters)

For the removal of most carpet adhesives.  
Estimated Production Rates: 100-300 sq.ft/hr  
Estimated Cutter Life: 1200-1500 sq.ft

### ADHESIVES – TILE

#### R138 (A-3, B-3 Cutters)

For the removal of most tile adhesives.  
Estimated Production Rates: 100-250 sq.ft/hr  
Estimated Cutter Life: 1200-1500 sq.ft

### CONCRETE GRINDING

#### R150, R151, or R152 (Carbide Cutters)

For the smoothing of rough concrete and/or grinding of high spots.  
Estimated Production Rates: 200-500 sq.ft/hr  
Estimated Cutter Life: 3000-6000 sq.ft

### CONCRETE SCARIFYING/GRINDING

#### R134 or R139 (Tungsten Carbide Tipped Cutters)

For preparation of concrete prior to the application of coatings or concrete overlay (1/8" depth of cut per pass.).  
Estimated Production Rates: 200-400 sq.ft/hr  
Estimated Cutter Life: 8000-15,000 sq.ft

### LINE REMOVAL

#### R132 (B-2)

For the removal of painted lines from concrete or asphalt.  
Estimated Production Rates: 10-20 linear ft/min  
Estimated Cutter Life: 800-2000 linear ft.

### LINE REMOVAL – THERMOPLASTIC

#### R143 (B-3)

For the removal of thermoplastic based paints from concrete or asphalt.  
Estimated Production Rates: 10-20 linear ft/min  
Estimated Cutter Life: 800-1200 linear ft.

## TYPICAL APPLICATIONS

- Asphalt leveling and grooving
- Carpet backing removal
- Coating removal
- Concrete grinding
- Concrete & steel surface preparation
- Concrete grooving
- Epoxy removal
- Expansion joint leveling
- Floor cleaning steel & concrete
- Glue/adhesive removal
- Milling joints

## TYPICAL APPLICATIONS (Cont.)

- Non-slip removal
- Paint removal
- Steel de-scaling
- Traffic line removal
- Wheelchair ramp leveling

## ASSEMBLY INSTRUCTIONS

Your new Bartell Surface Preparation System has been shipped to you fully assembled with some exceptions. Gas powered units require only filling with fuel and a brief check of lubricant levels in preparation for operation. Engine crank case is not pre-serviced with oil at the factory: levels should be checked. Electric Power Units are pre-wired at the factory and require only properly sized extension cable and fusing to comply with local by-laws.

To facilitate assembly of handles for various models together with the respective kill switch, electric harness or air valve, see the appropriate section for your machine.

### 1) HANDLE INSTALLATION

- Remove the pin (67) from the handle assembly. Align the lift plate (68) and re-insert the top pin (67). Place flat washer (64) on pin. Insert spring clip (126) through hole in pin. Feed threaded bolt end of cable (61) through hole on lift plates.

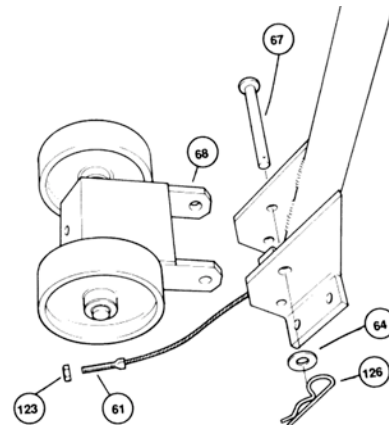

- Tighten cable by attaching nut (123).

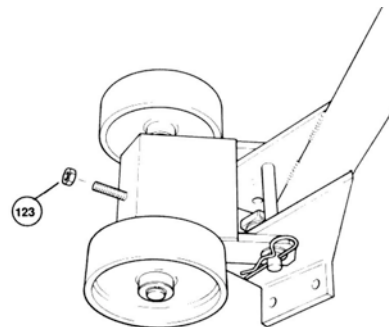

# SURFACE PREPARATION SYSTEM OWNER'S MANUAL & PARTS BOOK

## ASSEMBLY INSTRUCTIONS (Cont.)

- c. Remove the four bolts (70) and lock washers (69) from machine housing (104). Match up the holes on the handle assembly to the machine housing and insert the bolts (70) and the washers (69). Tighten bolts corner-to-corner. Before final tightening, place the machine on a flat surface to ensure all wheels contact the surface.

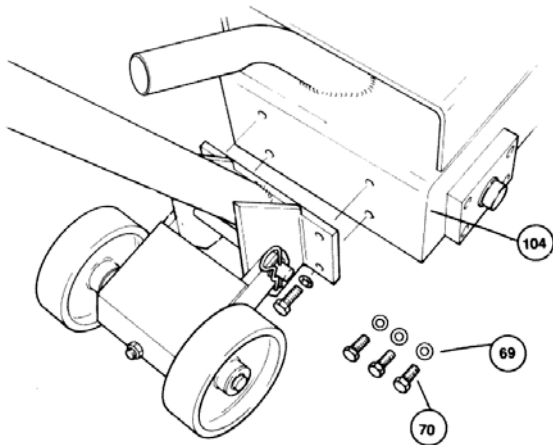

## 2) EDGER INSTALLATION

Make sure that the power source is disconnected; unplug the electric unit; disconnect spark plug and turn off fuel supply on gas unit; disconnect air supply on air unit.

1. Tilt machine back onto handle (if your unit is equipped with a Honda GX engine, unit must be tilted forward or cylinders will be flooded with oil).

2. Remove cutter cage and retainer shaft.
3. Facing underside of machine, slide dummy shaft (110) through outboard bearing on left side (if engine is a Honda GX this will be on the right side of the housing).
4. Slide retainer shaft (108) through edger cage. The roll pin in the shaft head should fit into the slot on the end plate of the cage.
5. Slide retainer shaft through the outboard bearing and the dummy shaft.
6. Using a 15/16" socket or wrench tighten the retainer shaft by turning counter clockwise.
7. Install edger housing (106) using the three bolts supplied (107).
8. NOTE: Edger operation is not to be performed with main SPS cage in place.

## 3) STOP-SWITCH INSTALLATION

- a. On gas powered models, feed the attached stop wire under the bridge and through the circular hole on the machine housing, from below engine, up to attached terminal on the engine. Secure it to the terminal by clamping with a pair of pliers.
- b. On electric models, attach bracket to the handle with screws and lockwashers provided. Wiring diagrams shown are for reference only: Figure 2a is for 220 volt and figure 2b is for 440 volt.

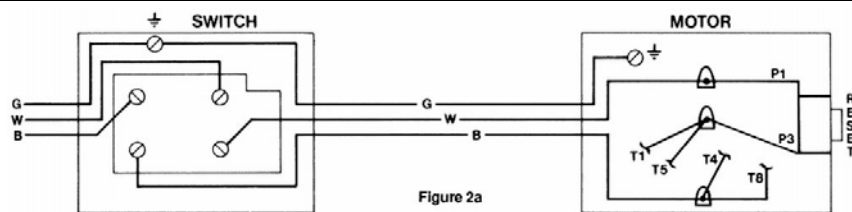

Figure 2a

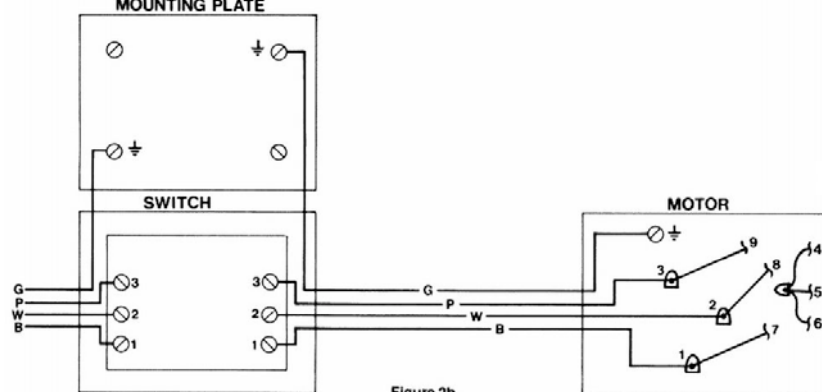

Figure 2b

# SURFACE PREPARATION SYSTEM OWNER'S MANUAL & PARTS BOOK

## **STARTING PROCEDURE (GAS OPERATED):**

### **\* WARM CLIMATE**

**IMPORTANT:** Set the machine in an upright position and adjust the cutter cage to maximum height by turning the height adjustment knob (51) to its farthest position. (This will ensure clearance for the rotation cage.)

Open fuel valve on gas tank. Set throttle lever to "Fast" idle position, set choke to closed position, start engine. Open choke slightly to prevent flooding. Move to "Open" or "Run" position when engine is warm, increase throttle to maximum operation position (3600 rpm).

## **STARTING PROCEDURE (GAS OPERATED):**

### **\* COLD CLIMATE**

With the machine in upright position, follow same procedure as above but allow longer warm-up period – 3 to 5 minutes. In cold weather, oil is much heavier to move and requires more time to work its way into the moving parts. If maximum power is not attained, allow further warm-up time. Fill fuel tank with clean gasoline, use safety approved gas containers. **DO NOT MIX OIL WITH GASOLINE (USE UNLEADED GAS ONLY.)**

## **STARTING PROCEDURE (ELECTRIC):**

With the cage in maximum raised position, plug in power cord to power source. Press the start button. Run-in for two (2) minutes. Press the stop button, then re-start. Ensure your cable is of sufficient size to run the motor properly. (14/3 type S for 220 volt; 16/3 type S for 440 volt.)

## **STARTING PROCEDURE (AIR):**

With cage in maximum raised position, attach air supply (minimum 90 C.F.M. at 90 P.S.I.) turn quick opening valve on. Run in for two (2) minutes. Turn off valve, then re-start. The air regulator is equipped with a pressure gauge. The recommended operating pressure is 90 P.S.I. at 90 C.F.M.; however when the unit is running with no load (cutters not engaged) the gauge will read 40 P.S.I. When the cutters are engaged the indicator needle should rise to 90 P.S.I.

## **STOPPING PROCEDURE:**

With machine in upright position, adjust the cutter cage to maximum height by turning the height adjustment knob (51) to its farthest position. (This ensures clearance for the rotating cage.)

**GAS UNIT** – Stop engine by depressing kill switch button (53) located at top of handle.

**AIR UNIT** – Turn off air supply valve (25).

**ELECTRIC UNIT** – Turn off switch on handle (11).

## **MAINTENANCE**

The SPS Machine is generally run in very dusty conditions. Engine life will be extended by maintaining a clean engine and using a dust control system. See owners manual for a complete maintenance schedule.

**AIR CLEANER (GAS UNIT)** – Keep air filter clean at all times. Wash away dust and debris using a non-oil based cleaning solvent. Let the filter dry before re-installing.

## **MAINTENANCE (Cont.)**

**LUBRICATION** – Always check engine oil regularly. Use proper engine oil as recommended. See chart below. Fill crankcase to levels as recommended in manufacture's engine manual.

**SPARK PLUG (GAS UNIT)**– Check and clean spark plugs regularly. A fouled, dirty or carboned spark plug causes hard starting and poor engine performance. Set spark plug gap to recommended clearance. Refer to engine manual.

### **BELT TENSION – IMPORTANT!**

If there is excessive belt play, there will be a decrease in the cutting/grinding action, which could cause cage and machine damage. The normal belt play should be 3/8" to 1/2" which is attained by depressing the top section of the belt at the belt guard mounting bracket location. When adjusting the belt make sure that the drive pulley is in alignment with cage pulley. Tighten all engine mount bolts, adjust the two engine-stop bolts, and tighten lock nuts.

**DRIVE SHAFT** – Keep a coating of grease on the drive shaft and threads for easy installation or removal and longer bushing life.

**SPOT CHECKS** – Perform as required. Machine should be inspected with ignition in "OFF" position or power disconnected. Do not perform inspections while machine is running.

- Check all fasteners for tightness – machine is subject to vibration.
- Check "V" belt for wear; adjust or replace as required.
- Check that wheels are clean and rotation freely.
- Check that inside of housing is clean; remove any build-up as required.
- Check that pulleys are aligned properly to ensure that "V" belt is running true. (i.e. not at an angle.)

## BEARING REPLACEMENT PROCEDURES

**IMPORTANT:** Disengage power supply. Do not attempt replacement while machine is operable.

### A) SEALED BEARING REPLACEMENT – OUTBOARD SIDE

Remove drive shaft and cutter cage assembly as per cutter change procedure below. Loosen and remove bearing block flange by removing screws and lockwashers. Using a soft drift, drive out and remove old bearing. Clean parts which will be re-used. Carefully press new bearing into flange. Take extreme care to maintain aligned installation. Do not press sleeve into position if misaligned. Mount bearing block to side of housing and tighten bolts when bearing block is in a free spin position.

### B) BEARING REPLACEMENT – DRIVER OR “V” BELT SIDE

Remove belt guard and “V” belt. Loosen two set screws, remove pulley and remove key. Remove bearing block assembly by removing screws and lock washers. Remove snap ring and slip ring. Using a soft drift, drive out spindle. Take care not to burr or flare spindle. Remove cover plate being certain the plate fits flush. Carefully press new bearing into block, clean and install bearing cover plate. Press drive spindle into block. Install slip ring and snap ring. Center and install spindle assembly to housing. Re-install pulley and key. Ensure pulley butts flush against shoulder or spindle. **NOTE:** When removing spindle or sleeve, care must be taken not to damage or distort these parts. A soft drift is recommended to prevent damage.

## CUTTER CAGE REMOVAL & CUTTER CHANGE

To remove the cutter cage from the machine.

1. Make sure that the power source is disconnected. With gas models turn off fuel supply to engine and disconnect sparkplug; unplug electric unit; disconnect air supply on air unit.
2. Tilt machine back onto the handle. (If your unit is equipped with a Honda GX engine, unit must be tilted forward to change cutters or cylinders will be flooded with oil).

## CUTTER CAGE REMOVAL & CUTTER CHANGE (Cont.)

3. Facing the underside of the machine housing (figure 3-A) place a bar between the cutter rods to jam cage C.
4. Remove end cap and with a 1” (26 mm) socket loosen and remove the shaft by turning in clockwise direction.  
OR  
Remove end cap and shaft guard to insert a drift pin into the hole on the main shaft B and turn shaft clockwise to loosen and remove shaft.
5. Disengage the cage from the drive pins by moving to the left. (The cage on the Honda GX machines will move to the right). Remove cage.

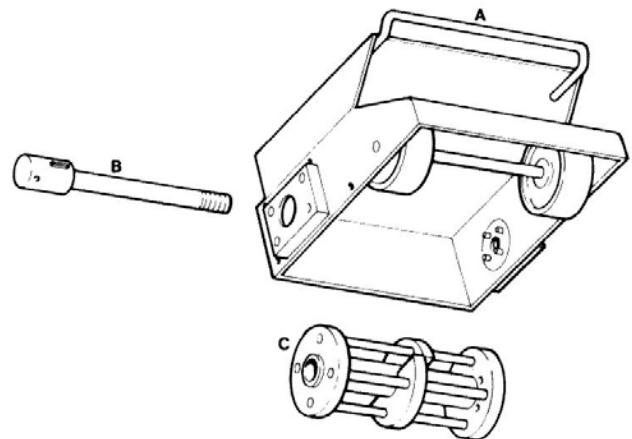

**Figure 3-A**

## EDGER CAGE REMOVAL

1. Make sure that the power source is disconnected. With gas models turn off fuel supply to engine and disconnect sparkplug; unplug electric unit; disconnect air supply on air unit.
2. Tilt machine back onto handle. (If your unit is equipped with a Honda GX engine, unit must be tilted forward to change cutters or cylinders will be flooded with oil).
3. Using a 15/16” socket or wrench, turn head of shaft (G) clockwise to loosen.
4. While turning the shaft outwards, cage will move towards the outer edge as well. Free cage from locking pins on shaft by pushing cage back towards main housing (A). turn shaft out and move.
5. Cage will be free to remove from edger.

# SURFACE PREPARATION SYSTEM OWNER'S MANUAL & PARTS BOOK

## CHANGING CUTTERS/SHAFTS

Once the cage has been removed use a 5/32" Allen Key and 7/16" open end wrench, remove screws and cover plate from cage. With drift pin tap rods from the drive side until free of cage. Replace cutters or shafts as required. Replace cover plate. To re-install cutter cage in machine, reverse procedure for removal. Ensure that the shaft is tight.

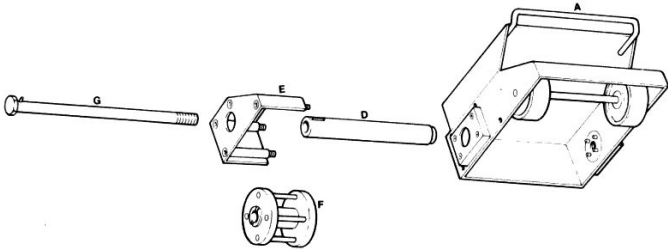

## STORAGE - Before

The following steps should be taken to prepare your SPS gas unit for extended storage.

1. Close fuel shut off valve.
2. Remove excess gasoline from tank.
3. Start engine until it stops from lack of fuel. This will use up all the fuel in the carburetor and prevent formation of deposits due to evaporation of fuel.
4. Remove spark plug and pour 2 oz. of SAE-30 or SAE-40 motor oil into the cylinder. Slowly crank the engine 2 or 3 times to distribute the oil throughout the cylinder. This will help prevent rust during storage. Replace spark plug.
5. Store the unit in an upright position in a cool, dry, well ventilated area.

## STORAGE - After

The following steps are recommended to ensure a smooth, proper startup after a prolonged storage.

1. Refuel
2. Open shut off valve
3. Start engine. Any excess oil residue will quickly burn off without harming operation.

## LUBRICATION

### ENGINE OIL

Always check engine oil before starting and at regular intervals thereafter. Use proper engine oil as recommended – see chart below. Keep engine oil clean, change accordingly. Fill crankcase to levels as recommended in manufacturer's engine manual.

<u>Season Temperature</u>	<u>Grade of Engine Oil</u>
All Seasons	SAE 10W-30

# **ASSEMBLY DRAWINGS AND PARTS LIST**





**SP8 GAS ASSEMBLY**

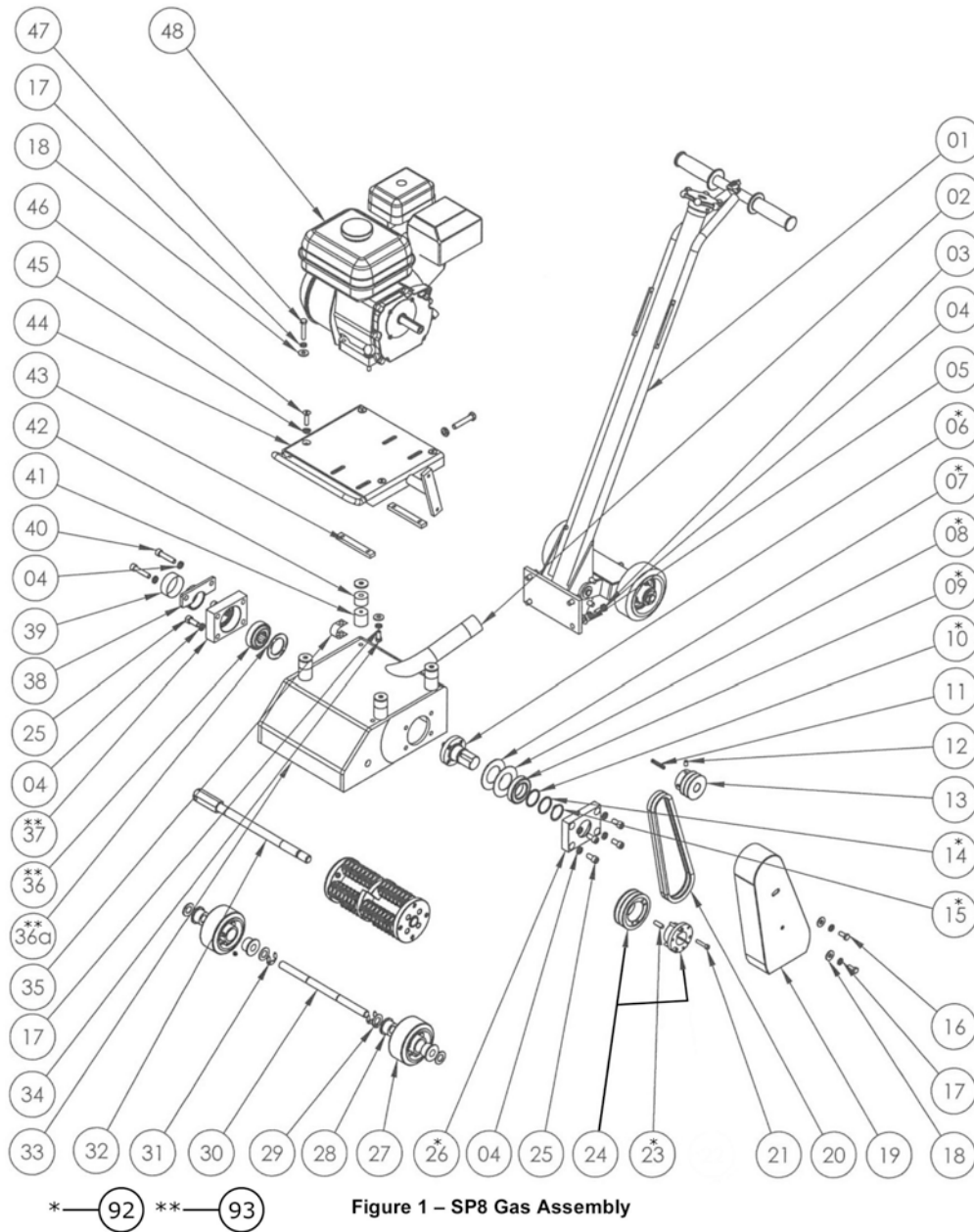

**Part 36, 36a & 37 = 30266 End Flange Assembly**



# SURFACE PREPARATION SYSTEM OWNER'S MANUAL & PARTS BOOK

## SP8 Gas Assembly

ITEM NO	PART NO	DESCRIPTION (SP8 GAS ASSEMBLY)	QTY	REMARK
01	30290	SPS HANDLE ASSM	1	06-23-2004
02	50444	EXHAUST CAP	1	
03	30284	SHCS, M10-1.5x25MM	6	06-23-2004
04	11621	LOCKWASHER, M10	12	06-23-2004
05	30282	SHCS M10-1.5 x 20mm	4	06-23-2004
06	30213	DRIVE SPINDLE (PART OF ITEM 92)	1	06-23-2004
07	30245	BEARING COVER PLATE (PART OF ITEM 92)	1	06-23-2004
08	50544	FELT WASHER LARGE (PART OF ITEM 92)	1	
09	50004	BEARING (PART OF ITEM 92)	1	
10	50545	FELT WASHER SMALL (PART OF ITEM 92)	1	
11	10208	KEY - 3/16" SQ x 1-1/2"	1	
12	30280	SHSS, M8-1.25x10MM	2	06-23-2004
13	30212	PULLEY - DRIVE	1	06-23-2004
14	50546	RING SPACER (PART OF ITEM 92)	1	06-23-2004
15	50012	SNAP RING (PART OF ITEM 92)	1	
16	11747	HHCS, M8-1.25x16MM	2	
17	11614	LOCKWASHER, M8	10	
18	11667	WASHER, M8	6	
19	50522	BELT GUARD	1	
20	31222	BELT – 10X660Li	2	
	50523	BELT – 3VX280	2	04-24-2011
21	30281	HHCS, M6-1.0x25MM	3	06-23-2004
23	30218	KEY - 8MM SQ x 30MM (PART OF ITEM 92)	1	06-23-2004
24	30214	PULLEY - DRIVEN	1	06-23-2004
25	30282	SHCS, M10-1.5x20MM	6	06-23-2004
26	30292	DRIVE FLANGE (PART OF ITEM 92)	1	06-23-2004
27	50357	FRONT WHEEL - 4" DIA.	2	
28	50510	WHEEL BUSHING	4	
29	50351	WASHER, 5/8"	4	
30	50348	FRONT AXLE	1	
31	50350	SNAP RING - 5/8" EXT.	2	
32	30216	HEX DRIVE SHAFT	1	06-23-2004
33	30204	HOUSING	1	06-23-2004
34	31106	SHCS, M8-1.25 x 20	4	06-23-2004
35	50537	GROUND STRAP	1	
36	50482	BEARING, HEX ID (PART OF ITEM 93)	1	06-23-2004
36a	50485	FELT WASHER (PART OF ITEM 93)	1	
37	30293	END CAP FLANGE (PART OF ITEM 93) ASSM	1	06-23-2004
38	50611	SHAFT GUARD	1	
39	50615	END CAP	1	
40	30285	SHCS, M10-1.5 x 45MM	2	06-23-2004
41	30286	RUBBER MOUNT	4	06-23-2004
42	30287	SPACER	4	06-23-2004
43	30207	SLIDER NUT	2	06-23-2004
44	30206	MOUNTING PLATE	1	
45	50530	LOCKWASHER, 5/16", EXT. C'SUNK	4	
46	30291	FHSCS, M8-1.25 x 40MM	4	06-23-2004
47	10452	HHCS, M8-1.25 x 40MM	4	06-23-2004
48	21333	ENGINE, HONDA GX160	1	
49	30218	Key 8m x 8mm x 30mm	1	
92	30250	DRIVE FLANGE ASSM (ITEMS 6, 7, 8, 9, 10, 14, 15, 23, 26)	1	06-23-2004
93	30266	END FLANGE ASSM (ITEMS 36, 36a, 27)	1	06-23-2004

**SP8 Electric Assembly**

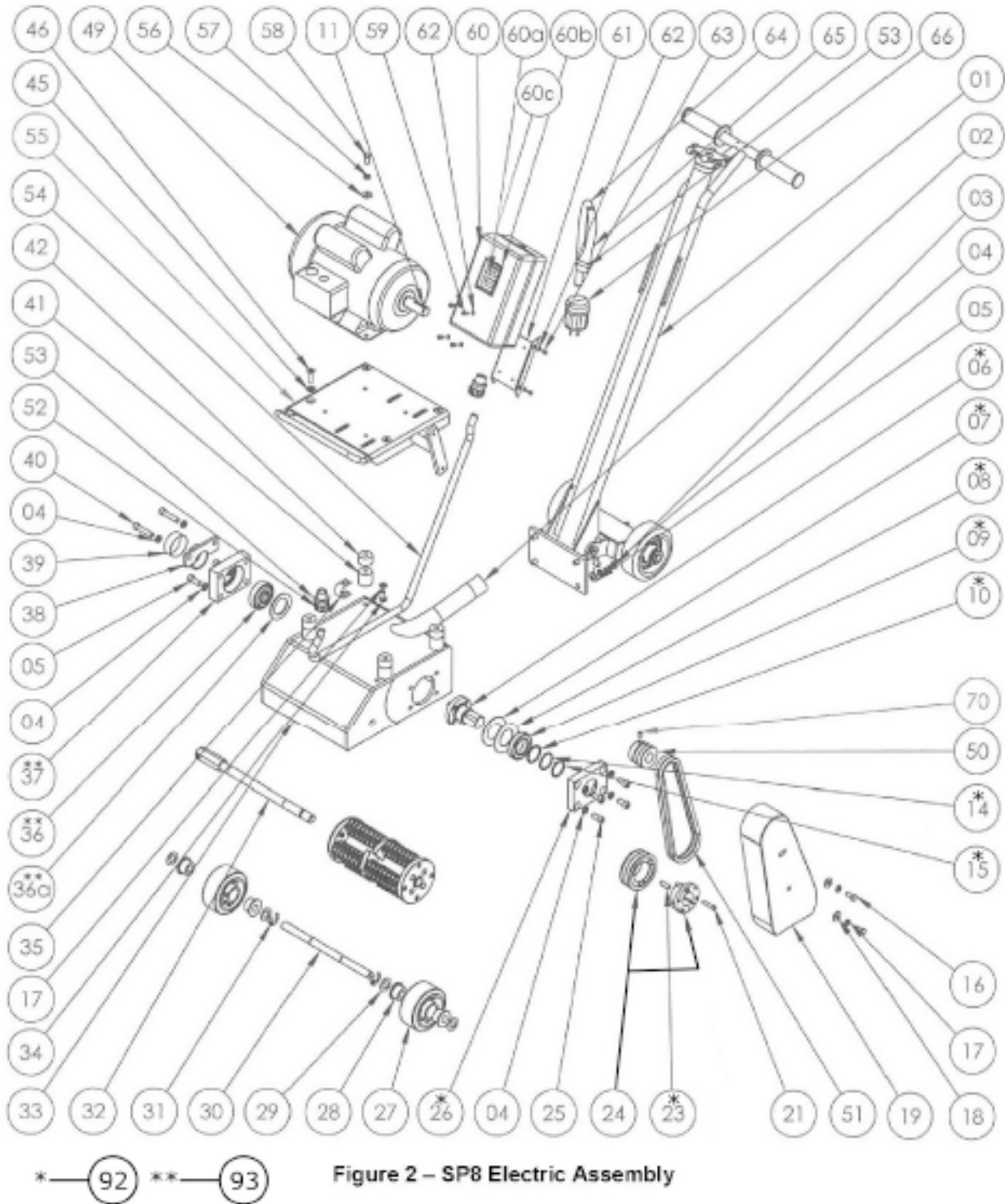

# SURFACE PREPARATION SYSTEM OWNER'S MANUAL & PARTS BOOK

## SP8 Electric Assembly

ITEM NO	PART NO	DESCRIPTION (SP8 ELECTRIC ASSEMBLY)	QTY	REMARK
01	30290	SPS HANDLE ASSM	1	06-23-2004
02	50444	EXHAUST CAP	1	
03	30284	SHCS, M10-1.5x25MM	6	06-23-2004
04	11621	LOCKWASHER, M10	12	06-23-2004
05	30289	WASHER, M10	4	06-23-2004
06	30213	DRIVE SPINDLE (PART OF ITEM 92)	1	06-23-2004
07	50093	BEARING COVER PLATE (PART OF ITEM 92)	1	
08	50544	FELT WASHER LARGE (PART OF ITEM 92)	1	
09	50004	BEARING (PART OF ITEM 92)	1	
10	50545	FELT WASHER SMALL (PART OF ITEM 92)	1	
11	10208	KEY - 3/16" SQ x 1-1/2"	1	
14	50546	RING SPACER (PART OF ITEM 92)	1	
15	50012	SNAP RING (PART OF ITEM 92)	1	
16	11747	HHCS, M8-1.25x16MM	2	06-23-2004
17	11614	LOCKWASHER, M8	10	06-23-2004
18	11667	WASHER, M8	6	06-23-2004
19	50522	BELT GUARD	1	
21	30281	HHCS, M6-1.0x25MM	3	06-23-2004
23	30218	KEY - 8MM SQ x 30MM (PART OF ITEM 92)	1	06-23-2004
24	30214	PULLEY - DRIVEN	1	06-23-2004
25	30282	SHCS, M10-1.5x20MM	4	06-23-2004
26	30292	DRIVE FLANGE (PART OF ITEM 92)	1	06-23-2004
27	50357	FRONT WHEEL - 4" DIA.	2	
28	50510	WHEEL BUSHING	4	
29	50351	WASHER, 5/8"	4	
30	50348	FRONT AXLE	1	
31	50350	SNAP RING - 5/8" EXT.	2	
32	30216	HEX DRIVE SHAFT	1	06-23-2004
33	30204	HOUSING	1	06-23-2004
34	31106	SHCS, M8-1.25 x 20	4	06-23-2004
35	50537	GROUND STRAP	1	
36	50482	BEARING, HEX ID (PART OF ITEM 93)	1	06-23-2004
36a	50485	FELT WASHER (PART OF ITEM 93)	1	
37	30293	END CAP FLANGE (PART OF ITEM 93)	1	06-23-2004
38	50611	SHAFT GUARD	1	
39	50615	END CAP	1	
40	30285	SHCS, M10-1.5 x 45MM	2	06-23-2004
41	30286	RUBBER MOUNT	4	06-23-2004
42	30287	SPACER	4	06-23-2004
45	50530	LOCKWASHER, 5/16", EXT. C'SUNK	4	
46	30291	FHSCS, M8-1.25 x 40MM	4	06-23-2004
49	50496	MOTOR - 2HP	1	
	50559	MOTOR - 3HP		

## SURFACE PREPARATION SYSTEM OWNER'S MANUAL & PARTS BOOK

### SP8 Electric Assembly (Con't)

ITEM NO	PART NO	DESCRIPTION (SP8 ELECTRIC ASSEMBLY, CON'T))	QTY	REMARK
50	50616	PULLEY – DRIVE (3HP)	1	
	50617	PULLEY – DRIVE (2HP)	1	
51	50524	BELT - 3VX265	2	
52	50085	STRAIN RELIEF	2	
53	50101	STRAIN RELIEF NUT	2	
54	50091	MOTOR CABLE - 51"	1	
55	30233	MOUNTING PLATE	1	
56	10919	WASHER, 5/16"	4	
57	10402	LOCKWASHER, 5/16"	4	
58	30142	HHCS, 5/16-18UNC x 3/4" LG	4	
59	50106	RHMS, #8-32 x 1/4"LG	4	
60	50090	STARTER BOX - 110V (2HP)	1	
	50187	STARTER BOX - 230V (3HP)		
	50764	STARTER BOX – 230V (3HP)		* 03-08-2011
60a	50760	MOTOR STARTER – 230V (3HP) (FOR 50764)	1	* 03-08-2011
60b	50762	SEALING KIT (FOR 50764)	1	* 03-08-2011
60c	50761	ENCLOSURE – 230V (3HP) (FOR 50764)	1	* 03-08-2011
61	50105	SWITCH PLATE	1	
62	50107	LOCKWASHER, INT. #8	8	
63	11035	PHMS, M4-0.7 x 10MM LG	4	06-28-2011
64	50092	MOTOR CABLE – 24"	1	
66	50087	PLUG – 220V (2HP)	1	
	50502	PLUG – 110V (2HP)		
	50592	PLUG – 220V (3HP)		
70	50117	SHSS,5/16"-18UNCx1/2"LG	2	
92	30250	DRIVE FLANGE ASSM (ITEMS 6, 7, 8, 9, 10, 14, 15, 23, 26)	1	06-23-2004
93	30266	END FLANGE ASSM (ITEMS 36, 36a, 37)	1	06-23-2004

\* Serial number 125416 and greater

# SURFACE PREPARATION SYSTEM OWNER'S MANUAL & PARTS BOOK

## SP8 Air Assembly

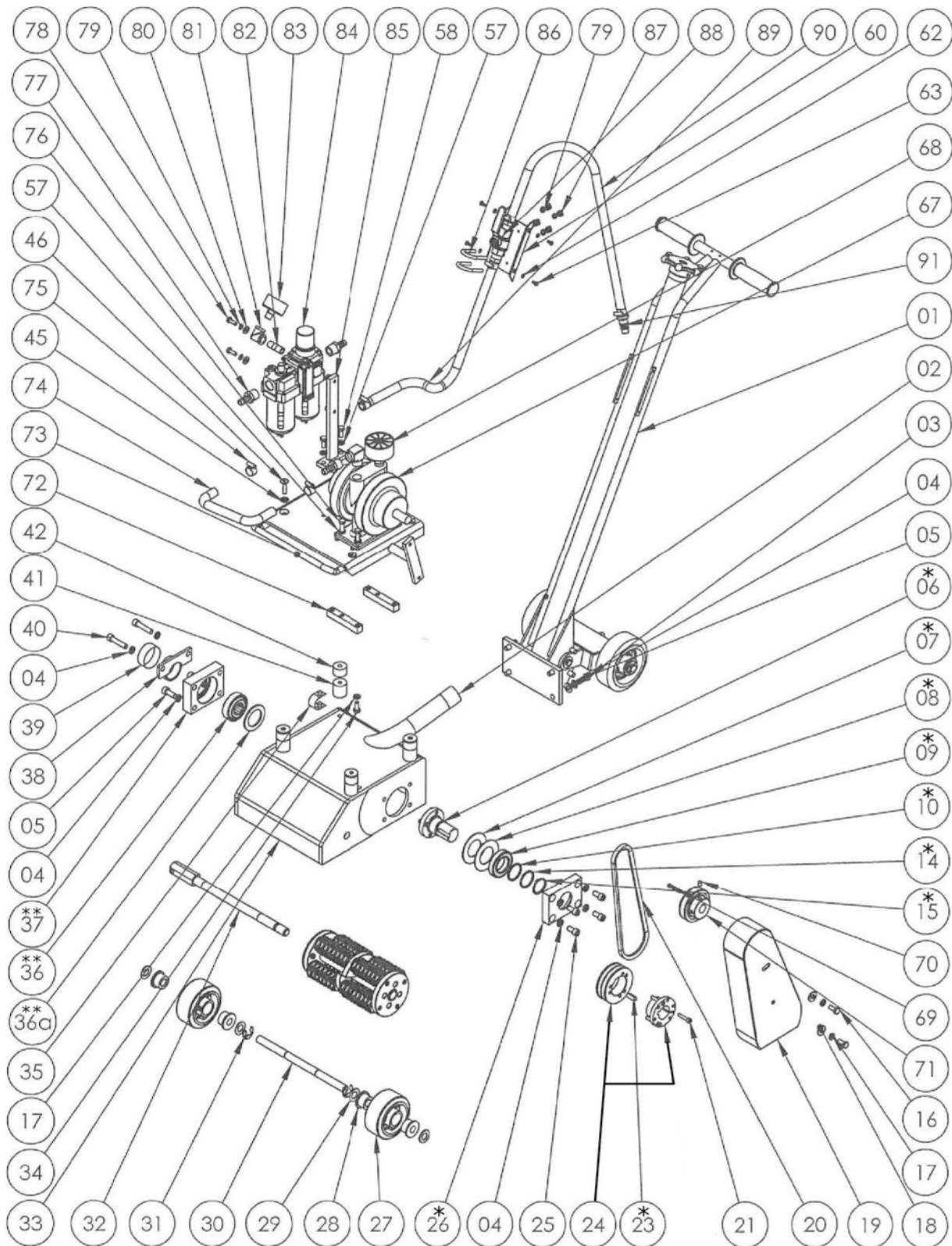

\* — (92)    \*\* — (93)

**Figure 3 – SP8 Air Assembly**

# SURFACE PREPARATION SYSTEM OWNER'S MANUAL & PARTS BOOK

## SP8 Air Assembly

ITEM NO	PART NO	DESCRIPTION (SP8 AIR ASSEMBLY)	QTY	REMARK
01	30290	SPS HANDLE ASSM	1	06-23-2004
02	50444	EXHAUST CAP	1	
03	30284	SHCS, M10-1.5x25MM	6	06-23-2004
04	11621	LOCKWASHER, M10	12	06-23-2004
05	30289	WASHER, M10	4	06-23-2004
06	30213	DRIVE SPINDLE	1	06-23-2004
07	50093	BEARING COVER PLATE	1	
08	50544	FELT WASHER LARGE	1	
09	50004	BEARING	1	
10	50545	FELT WASHER SMALL	1	
12	30280	SHSS, M8-1.25x10MM	2	06-23-2004
14	50546	RING SPACER	1	
15	50012	SNAP RING	1	
16	11747	HHCS, M8-1.25x16MM	2	
17	11614	LOCKWASHER, M8	10	
18	11667	WASHER, M8	6	
19	50522	BELT GUARD	1	
20	50523	BELT - 3VX280	1	06-23-2004
21	30281	HHCS, M6-1.0x25MM	3	06-23-2004
23	30218	KEY - 8MM SQ x 30MM	1	06-23-2004
24	30214	PULLEY - DRIVEN	1	06-23-2004
25	30282	SHCS, M10-1.5x20MM	4	06-23-2004
26	30292	DRIVE FLANGE	1	06-23-2004
27	50357	FRONT WHEEL - 4" DIA.	2	
28	50510	WHEEL BUSHING	4	
29	50351	WASHER, 5/8"	4	
30	50348	FRONT AXLE	1	
31	50350	SNAP RING - 5/8" EXT.	2	
32	30216	HEX DRIVE SHAFT	1	06-23-2004
33	30204	HOUSING	1	06-23-2004
34	31106	SHCS, M8-1.25 x 20	4	06-23-2004
35	50537	GROUND STRAP	1	
36	50482	BEARING, HEX ID	1	06-23-2004
36a	50485	FELT WASHER	1	
37	30293	END CAP FLANGE	1	06-23-2004
38	50611	SHAFT GUARD	1	
39	50615	END CAP	1	
40	30285	SHCS, M10-1.5 x 45MM	2	06-23-2004
41	30286	RUBBER MOUNT	4	06-23-2004
42	30287	SPACER	4	06-23-2004
45	50530	LOCKWASHER, 5/16", EXT. C'SUNK	4	
46	30291	FHSCS, M8-1.25 x 40MM	4	06-23-2004
47	10452	HHCS, M8-1.25 x 40MM	4	06-23-2004
57	10402	LOCKWASHER, 5/16"	4	
58	30142	HHCS, 5/16-18UNC x 3/4" LG	2	

# SURFACE PREPARATION SYSTEM OWNER'S MANUAL & PARTS BOOK

## SP8 Air Assembly (Con't)

ITEM NO	PART NO	DESCRIPTION	QTY	REMARK
61	50105	SWITCH PLATE	1	
62	50107	LOCKWASHER, INT. #8	8	
63	11035	PHMS, M4-0.7 x 10MM LG	4	06-28-2011
67	50377	GAST 8 AIR MOTOR	1	
68	50380	MUFFLER	1	
69	50309	KEY, 3/16" SQ x 1-1/4"	1	
70	50117	SHSS, 5/16"-18UNCx1/2"LG	2	
71	50532	PULLEY - DRIVE	1	
72	50551	SLIDING NUT, AIRMOTOR	2	
73	50516	MOUNTING PLATE	1	
74	50180	MOTOR HOSE - 6"	1	
75	50161	HOSE CLAMP, 1/2"	6	
76	30008	HHCS, 5/16-18UNC x 1-3/4"	4	
77	50163	HOSE FITTING, 1/2"	5	
78	10392	HHCS, 1/4"-20 x 3/4"	2	06-28-2011
79	50363	LOCKWASHER, 1/4"	6	06-28-2011
80	11043	WASHER, 1/4"	2	06-28-2011
81	50117	FITTING, 90 DEG. ELBOW, 1/4NPT	1	
82	50175	1/4" NIPPLE	1	
83	50176	GAUGE	1	
84	50494	AIR REGULATOR	1	
85	50493	REGULATOR BRACKET	1	
86	50165	VALVE CLAMP	2	
87	10582	NUT, SQUARE, 1/4-20UNC	2	
88	50164	BALL VALVE 1/2"	1	
89	50170	REGULATOR HOSE 20"	1	
90	50162	EXTENSION HOSE 30"	1	
91	50160	QUICK COUPLING 1/2"	1	
92	30250	DRIVE FLANGE ASSM (ITEMS 6, 7, 8, 9, 10, 14, 15, 23, 26)	1	06-23-2004
93	30266	END FLANGE ASSM (ITEMS 36, 36a, 37)	1	06-23-2004



Handle Assembly - 30290

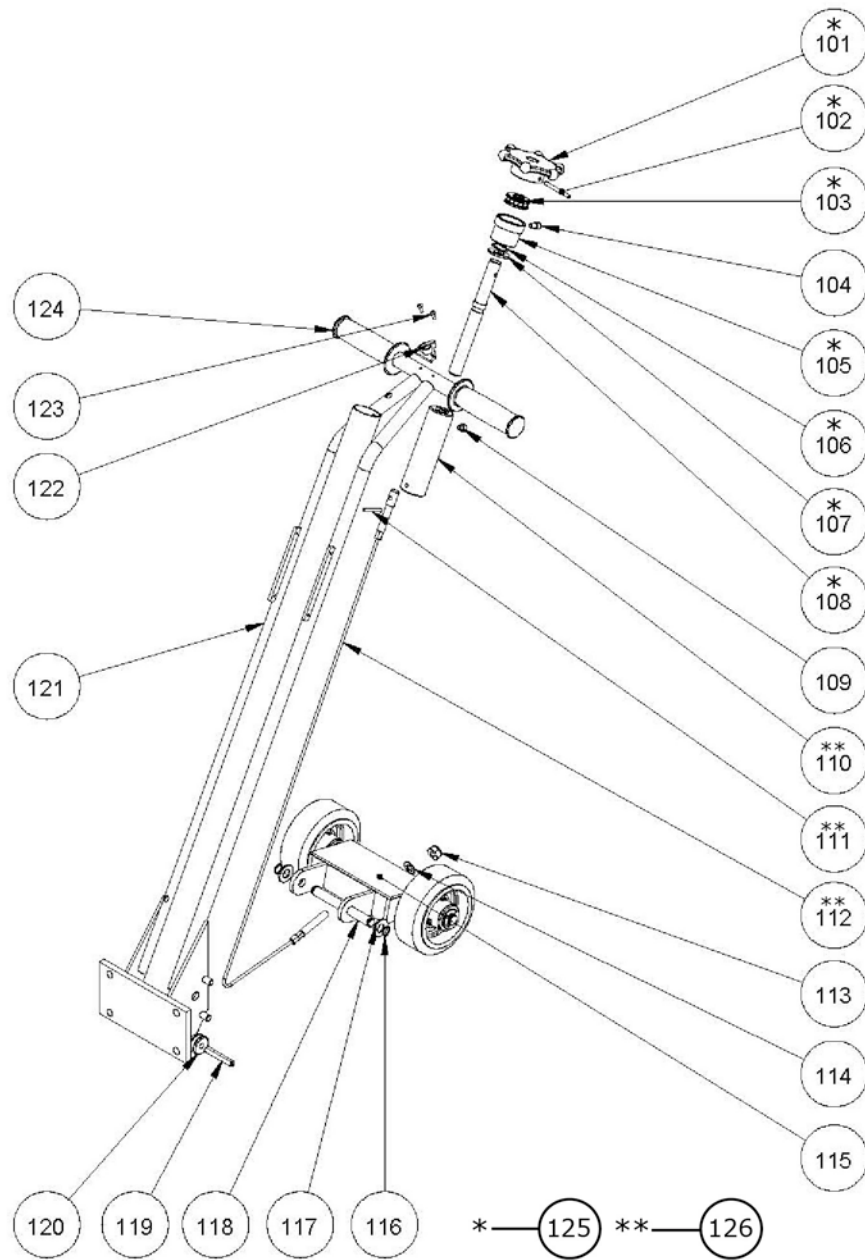

Figure 4 - Handle Assembly



# SURFACE PREPARATION SYSTEM OWNER'S MANUAL & PARTS BOOK

## Handle Assembly - 30290

ITEM NO	PART NO	DESCRIPTION	QTY	REMARK
101	30294	HAND KNOB	1	06-23-2004
102	30295	SPRING PIN, M5 x 48MM	1	06-23-2004
103	30210	BEARING	1	06-23-2004
104	21727	SHCS,M6-1 x12MM	1	06-23-2004
105	30209	BUSHING	1	06-23-2004
106	50266	WAVE WASHER	1	06-23-2004
107	10306	WASHER	1	06-23-2004
108	30208	SCREW SHAFT	1	06-23-2004
109	21725	SHCS, M6-1 x 6MM	1	06-23-2004
110	30205	SLIDE BUSHING	1	06-23-2004
111	30302	SPRING PIN, M5 x 35MM	1	06-23-2004
112	30296	CABLE, PITCH CONTROL	1	06-23-2004
113	11802	LOCKNUT, M10-1.5	1	06-23-2004
114	41516	WASHER, M10	1	06-23-2004
115	30310	REAR WHEEL ASSY	1	06-23-2004
116	50025	SNAP RING	2	06-23-2004
117	50026	WASHER - 1/2"	2	06-23-2004
118	50531	PIN, LIFT PLATE	1	06-23-2004
119	30298	SPRING PIN, M8 x 35MM	1	06-23-2004
120	30299	PULLEY	1	06-23-2004
121	30300	SPS HANDLE TUBE	1	06-23-2004
122	30303	STOP SWITCH CORD ASSY	1	06-23-2004
123	11035	SCREW, M4-0.7 x 10MM	2	06-23-2004
124	30301	HANDLE GRIPS	2	06-23-2004
125	30279	HAND KNOB ASSY (ITEMS 101-103, 105-108)	1	06-23-2004
126	30240	CABLE ASSY (ITEMS 110-112)	1	06-23-2004

# SURFACE PREPARATION SYSTEM OWNER'S MANUAL & PARTS BOOK

## Rear Wheel Assembly - 30310

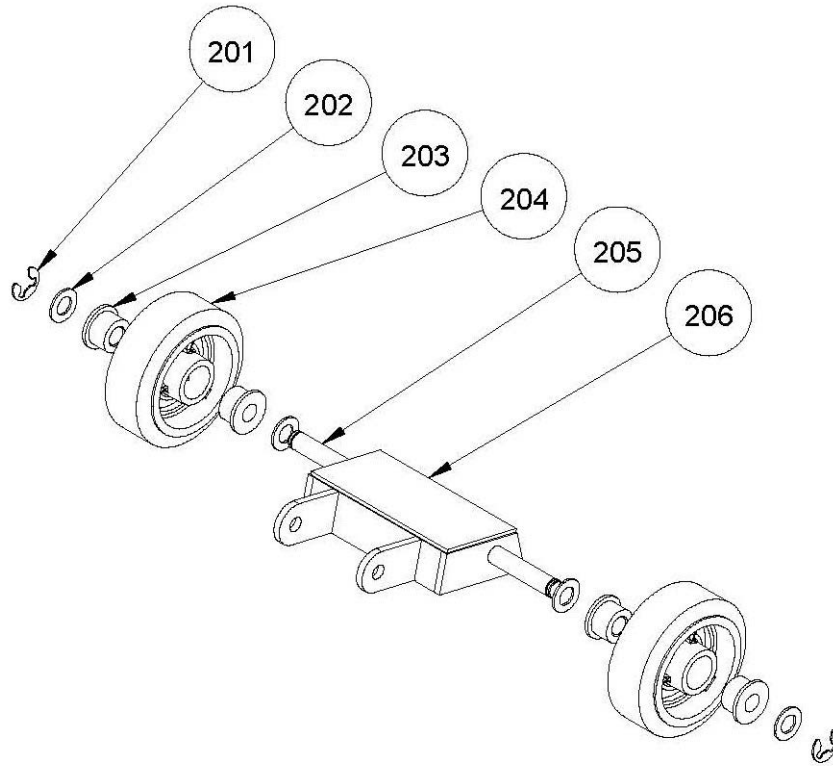

**Figure 5 – Rear Wheel Assembly**

ITEM NO	PART NO	DESCRIPTION (REAR WHEEL ASSEMBLY)	QTY	REMARK
201	50350	SNAP RING	1	06-23-2004
202	50351	WASHER - 5/8"	4	06-23-2004
203	50510	WHEEL BUSHING	4	06-23-2004
204	50356	REAR WHEEL - 5" DIA.	2	06-23-2004
205	50349	REAR AXLE	1	06-23-2004
206	30297	LIFT PLATE	1	06-23-2004

**Edger and Edger Cage Assembly**

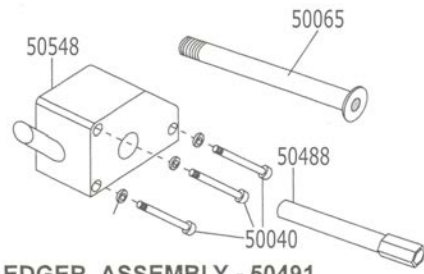

**EDGER ASSEMBLY - 50491**

**Figure 6**

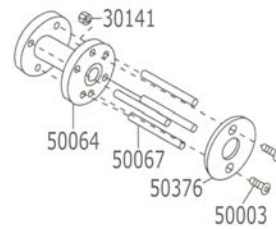

**EDGER CAGE ASSEMBLY - 50083**

**Figure 7**

**Cage Assemblies**

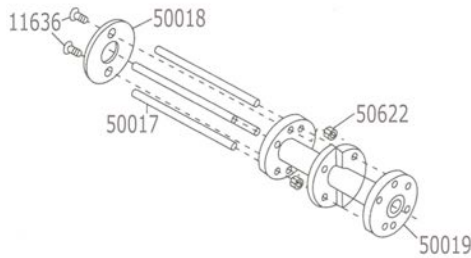

**"A" CAGE ASSEMBLY - 50078**

**Figure 8**

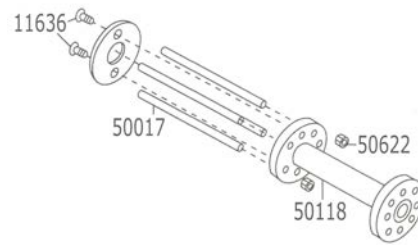

**"B" CAGE ASSEMBLY - 50146**

**Figure 9**

# SURFACE PREPARATION SYSTEM OWNER'S MANUAL & PARTS BOOK

## TROUBLESHOOTING GUIDE

PROBLEM	CAUSE	SOLUTION
<b>AIR UNIT</b>  1. Air supply inconsistent 2. Ice forming in air exhaust  3. Low R.P.M.	<ul style="list-style-type: none"> <li>• Leak in air lines</li> <li>• Water in air supply</li> <li>• Insufficient air flow</li> </ul>	<ul style="list-style-type: none"> <li>• Tighten connections</li> <li>• Check auto drain, refer to engine manual</li> <li>• SP8-A: Adjust large knob on top of regulator by pulling outer ring of control upwards and turning clockwise. Once adjusted, push ring down to lock in position.</li> </ul>
<b>ELECTRIC UNIT</b>  1. Unit running slow  2. Unit won't run	<ul style="list-style-type: none"> <li>• Voltage drop</li> <li>• Fuse blown</li> <li>• Power disconnected</li> <li>• Cold cut</li> <li>• Other</li> </ul>	<ul style="list-style-type: none"> <li>• Check power supply</li> <li>• Check extension cord size and length (max. 150 ft.)</li> <li>• Check fuses</li> <li>• Check plug</li> <li>• Check cord</li> <li>• Refer to motor manual</li> </ul>
<b>GAS UNIT</b>  1. Engine won't start	<ul style="list-style-type: none"> <li>• No fuel</li> <li>• Engine switch off</li> <li>• Low oil level</li> <li>• Kill switch shorted to ground</li> <li>• Gas in air filter or carburetor</li> </ul>	<ul style="list-style-type: none"> <li>• Refuel</li> <li>• Engine switch on</li> <li>• Add oil</li> <li>• Repair short</li> <li>• Remove air filter, crank engine</li> <li>• Refer to engine manual</li> </ul>
<b>COMMON PROBLEMS</b>  1. Cutters wearing unevenly  2. Drive shaft backs out while running  3. Machine jumps on floor  4. "V" belt wearing rapidly  5. Uneven cut	<ul style="list-style-type: none"> <li>• Cage too low</li> <li>• Wrong setup</li> <li>• Material buildup</li> <li>• Cutters too tight</li> <li>• No grease on threads</li> <li>• Not tightened properly</li> <li>• Cage lowered too far</li> <li>• R.P.M. too low</li> <li>• Pulley misaligned</li> <li>• Wrong belt</li> <li>• Belt rubbing on surface</li> <li>• Wear on I.D. of front wheels</li> <li>• Wear on front axle</li> </ul>	<ul style="list-style-type: none"> <li>• Raise cage</li> <li>• See applications guide</li> <li>• Clean or change cutters</li> <li>• Cutters too tight</li> <li>• Grease threads</li> <li>• Adjust height knob to raise cage</li> <li>• Reset throttle</li> <li>• Adjust pulley</li> <li>• Replace with proper belt</li> <li>• Adjust height of machine</li> <li>• Replace wheels</li> <li>• Replace axle</li> </ul>

## SURFACE PREPARATION SYSTEM OWNER'S MANUAL & PARTS BOOK

<i>APPLICATION</i>	<i>CUTTER</i>	<i>CAGES</i>
Adhesive Removal	A-2, B-2 alone or combined A-2/B-2 or A-3/B-3 combined	R121, R125, R137, R138, R142
Asphalt leveling and grooving	B-2, B-3, A-3, alone or combined A-3/B-3	R122, R122, R126, R132, R138, R149
Carpet backing removal	A-2, B-2, or combined A-2/B-2 or A-3/B-3 combined	R121, R125, R137, R138, R142
Coating removal	B-2, B-3, A-3, TCT's	R121, R122, R138, R134, R139
Concrete grinding	A-3, or TCT's	R126, R134, R139
Concrete & steel surface preparation	A-3, B-1, B-2, alone	R122, R126, R155
Concrete grooving	B-3, TCT's	R123, R149
Epoxy removal	B-2, B-3, alone	R122, R137, R138
Expansion joint leveling	TCT cutters	R134, R139
Floor cleaning steel & concrete	B-1, B-2, B-3 alone or A-3/B-3	R120, R126, R137, R138
Line removal	B-2, B-3, TCT's, Carbide Flails	R132, R143, R160, R161, R162, R163
Milling joints	TCT's	R123, R134, R139
Non-slip removal	A-3 alone or A-3/B-3	R126, R138
Paint removal	B-1, B-2, B-3, A-2, or A-3/B-3	R121, R122, R125, R137, R138, R155
Steel de-scaling	A-3, A-3/B-3	R126, R138
Wheelchair ramp leveling	TCT's	R134, R139



# SURFACE PREPARATION SYSTEM OWNER'S MANUAL & PARTS BOOK

## SPECIFICATIONS

### SURFACE PREPARATION SYSTEM

SP8 – Walk behind surface grinder/scarifier with a cutting width up to 8" (203 mm)

Model	Power Supply	Operating Weight (approx.)	Shipping Weight	Standard Cutting Width	Working Depth (per pass)
SP8-G	6 HP OHV Robin 5.5 HP OHV Honda	135 lbs. 61 kg	150 lbs. 68 kg	up to 8" (203 mm)	up to 1/16" (1.6 mm)
SP8-E	2 HP 110/220V Leeson Motor 3 HP 220V Leeson Motor	150 lbs. 68 kg	165 lbs. 75 kg	up to 8" (203 mm)	up to 1/16" (1.6 mm)
SP8-A	5 HP Gast 8 90 CFM at 90 PSI	135 lbs. 61 kg	150 lbs. 68 kg	up to 8" (203 mm)	up to 1/16" (1.6 mm)



# SURFACE PREPARATION SYSTEM OWNER'S MANUAL & PARTS BOOK

## Declaration of Conformity / Certificat de conformité / Gelijkvormigheids certificaat Declaración de Conformidad/Declaração de Conformidade/Dichiarazione Di Conformita

We: Bartell Morrison Inc.  
375 Annagem Blvd  
Mississauga, Ontario, Canada  
L5T 3A7  
Tel: 905-364-4200 Fax: 905-364-4201

Declare under our sole responsibility that the product to which this declaration relates is in conformity with the following standard(s) or other normative documents.

Déclarons sous notre responsabilité que le produit cette déclaration est conforme aux normes suivantes ou d'autres documents habituels.

Verklaren onder onze verantwoordelijkheid dat het product naar welke de verklaring verwijst conform de volgende standaards of anders gebruikelijke documenten is.

Declaramos bajo nuestra única responsabilidad que el producto en lo que esta declaración concierne, es conforme con la siguiente normativa u otros documentos.

Declara sob sua responsabilidade que o produto a quem esta declaração interessar, está em conformidade com os seguintes documentos legais ou normas directivas.

Dichiariamo sotto la ns. unica responsabilità che il prodotto al quale questa dichiarazione si riferisce, è fabbricato in conformità ai seguenti standard e documenti di normative.

EN 349:1993	Safety of Machinery - Minimum gaps to avoid crushing of parts of the human body.
EN 418:1993	Safety of Machinery - Emergency stop equipment, functional aspects - Principles for design
EN 12100-1:2003	Safety of Machinery - Basic Concepts, general principles for design - Part 1: Basic Terminology, methodology
EN 12100-2:2003	Safety of Machinery - Basic Concepts, general principles for design - Part 2: Technical Principles
EN ISO 4872:1978	Acoustics - Measurement of Airborne noise emitted by construction equipment intended for outdoor use - Method for determining compliance with noise limits.
EN ISO 5349-1:2001	Mechanical vibration. Measurement and evaluation of human exposure to hand-transmitted vibration. General requirements
EN ISO 5349-2:2001	Mechanical vibration. Measurement and assessment of human exposure to hand-transmitted vibration. Practical guidance for measurement at the workplace.

Following the provisions of Directive(s):

Suivant les directive(s) déterminées:

Volgens de vastgestelde richtlijnen:

Siguiendo las directiva(s):

No seguimento das clausulas da Directiva(s):

Seguendo quanto indicato dalla Direttiva(s):

2006/42/EC	Machinery Directive
2000/14/EC	Noise Directive
2001/95/EC	General Product Safety Directive
2002/95/EC	Reduction of Hazardous Waste Directive

# SURFACE PREPARATION SYSTEM OWNER'S MANUAL & PARTS BOOK

Technical Characteristics:  
 Caractéristiques techniques:  
 Technisch gegevens:  
 Características Técnicas:  
 Características Técnicas:  
 Qualitàs di tecnico:

Model Modèle Type Modelo Modelo Modello	Machine Serial Number Numéro de Série machine Serienummer machine Máquina número de série Numero de serie da maquina Numero di seria la macchina	Engine Serial Number Numéro de Série moteur Serienummer motor Motor número de série Numero de serie do motor Numero di seria la motore	Weight Masse Gewicht Masa Massa Massa
			Lbs (kg)

Noise Level Puissance acoustique Geluidniveau Nivel Sonoro Nivel del Ruido Potenza Acustica	Pressure level Pression acoustique Geluidsdrumniveau Nivel Acustico Pressão Acústica Pressione Acustica	Vibration level Niveau de vibration Vibratieniveau Nivel de Vibracion Nivel de Vibração Livello di Vibrazione
L <sub>wa</sub> (dB)	L <sub>pa</sub> (Db)	a <sub>hv</sub> (m/s <sup>2</sup> )

The Technical Construction file is maintained at:  
 Les fiches techniques de construction sont gardées à:  
 Het technische constructie document wordt bewaard te:  
 El archivo técnico de construcción se mantiene en:  
 O arquivo técnico de construção é mantido no (a):  
 L'originale dossier tecnico di costruzione è conservato presso:

Bartell Morrison Inc.  
 375 Annagem Blvd.  
 Mississauga, Ontario, Canada  
 L5T 3A7  
 Telephone: 905-364-4200  
 Facsimile: 905-364-4201  
 Mr. Steve Adam  
 International Sales Manager  
 C/o Bartell Morrison Europe  
 Nijverheidsstraat 11  
 1840 Londerzeel  
 Belgium  
 Telephone: +1 514 463 4838  
 Facsimile: +1 514 697 4239

The authorized representative is:  
 Le représentant autorisé est:  
 Gemachtigd vertegenwoordiger is:  
 La representación autorizada es:  
 O representante autorizado é:  
 Il rappresentate autorizzato:

Signature of Authorized Person:  
 Signature de la personne autorisée:  
 Handtekening van gemachtigd persoon:  
 Firma de la persona autorizada:  
 Assinatura de pessoa autorizada:  
 Firma della persona autorizzata:  
 Typed name of Authorized Person:  
 Nom dactylographié de la personne autorisée:  
 Getypte naam van gemachtigd persoon:  
 Nombre de la persona autorizada:  
 Nome datilografado da pessoa autorizada:  
 Nome della persona autorizzata:  
 Title of Authorized Person:  
 Titre de la personne autorisée:  
 Functie van gemachtigd persoon:  
 Cargo de la persona autorizada:  
 Título da pessoa autorizada:  
 Posizione della persona autorizzata:  
 Date and place of issue:  
 Date et place d'émission:  
 Datum en plaats van afgifte:  
 Fecha y lugar de emision:  
 Data e lugar de emissão:  
 Data e luogo di emissione:



Robert S. Leggitt

Manager - Engineering

7.30.2015

Mississauga, Ontario, Canada





